

**375 WATT**  
EMERGENCY POWER



MODEL NO: \_\_\_\_\_  
 TYPE: \_\_\_\_\_  
 PROJECT: \_\_\_\_\_  
 COMMENTS: \_\_\_\_\_

**LOAD CAPABILITY**

375 Watts

**FIXTURE TYPES**

Fluorescent  
Incandescent

**DESCRIPTION**

The IOTA **IIS 375 I** is a UL Listed stand-alone sine wave output inverter designed to provide power to designated emergency lighting fixtures. In a power loss situation, the IOTA **IIS 375 I** will supply **375W** of power from the onboard battery supply. The IOTA **IIS 375 I** works in conjunction with incandescent and fluorescent lamp and fixture types and will automatically run switched, normally-on, or normally-off designated emergency fixtures. The **IIS 375 I** is ideal for applications requiring an emergency source for lighting arrangements that utilize multiple lamp and fixture types. The **IIS 375 I** is available in a surface mount housing and comes with a three-year warranty and seven-year pro-rata battery warranty.

**SPECIFICATIONS**

Input Voltage .....	(Dual) 120/277V, 60Hz
Input Rating (bulk).....	500 Watts
Output Voltage .....	(Dual) 120/277V, 60Hz
Output Power .....	375 Watts (@ .9 leading to .9 lagging PF)
Lamps Operated .....	Fluorescent, Incandescent
Transfer Time .....	less than 1 second
Emergency Operation .....	90 minutes
Voltage Regulation (emergency).....	+/- 2% @ 15% to 110% load
Frequency Regulation (emergency).....	+/- .5%
Load Power Factor Range .....	.9 leading to .9 lagging
Operating Temp.....	20° to 30° C
Battery.....	Valve Regulated Lead Acid (VRLA)
Weight.....	114 lbs.
Approval.....	UL 924 Listed



**DIMENSIONS**

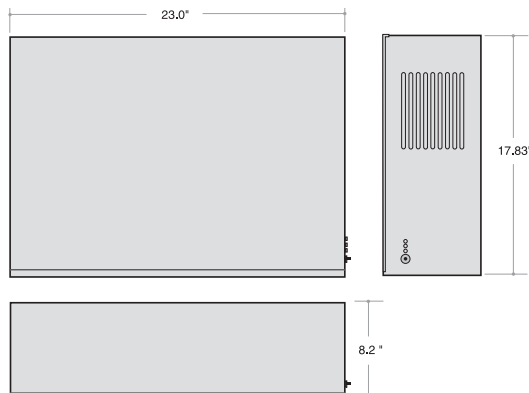

**FEATURES**

- Emergency lighting supplied from one convenient source
- Pure sine wave output
- Operates incandescent and fluorescent fixtures including fixtures with dimmable fluorescent ballasts
- Includes momentary contact test switch, yellow ready indicator, green inverter-on indicator, and red charging indicator
- Dual voltage 120/277 60Hz
- High efficiency pure sine wave inverter
- Variable-rate, temperature-compensated charger
- Valve Regulated Lead Acid (VRLA) battery provides long life and is maintenance free
- Line voltage allows for remote mounting of emergency fixtures at distances up to 1000 feet
- Resettable output circuit breaker provides protection against circuit overload
- Low Battery Voltage Disconnect and Line Latch Protection
- Allows for emergency operation of switched or unswitched fixtures.
- Meets or exceeds all National Electrical Code and Life Safety Code Emergency Lighting Requirements
- Durable 16-gauge steel housing design with white semi-gloss powder-coat paint finish
- 3/7 Pro-Rata Warranty

IIS INVERTERS



# IIS 375 I

375W SURFACE MOUNT UNIT INVERTER SYSTEM

## MODELS

- IIS 375 I

## COMPONENTS

- High-efficiency pure sine wave inverter
- Variable-rate, temperature-compensated charger
- 12V maintenance-free Valve Regulated Lead Acid (VRLA) battery

## CONSTRUCTION

- 16-gauge steel housing

## IIS 375 I SAMPLE SPECIFICATION

Emergency lighting shall be provided by inverter unit equipment designed to operate designated incandescent, fluorescent and LED\* fixtures on emergency power at their full nominal lumen rating during the full 90-minute emergency discharge cycle. System output will be rated at 375 watts for 90 minutes and provided with an output circuit breaker for protection of overload or load fault conditions. The system's voltage rating shall be field selectable 120 or 277 VAC input/output.

The inverter unit shall allow for connected emergency fixture(s) to be normally on, normally off, switched or dimmed without affecting lamp operation during a power failure. Upon utility power loss, the inverter unit shall operate the load at 100% of its full rated output regardless of the local switch position, and will provide power to emergency fixtures at distances of up to 1000 feet.

The housing shall be designed for surface mount installation requirements and manufactured using 16-gauge steel with a white hammer semi-gloss scratch-resistant baked-on powder coat paint finish.

The unit's electronics shall include a self-contained inverter section with a fully automatic, thermal-compensating variable-rate battery charger, AC lockout feature, low battery voltage disconnect, DC overload, short circuit and brownout protection as standard. The unit shall utilize a sealed lead calcium battery with a 10-year design life. The inverter system shall be UL 924 Listed and labeled. The unit shall be covered under a 3-year warranty on the electronics and battery and a 7-year pro-rata warranty on the battery. It shall meet or exceed the requirements of UL 924, NFPA 101 Life Safety Code, NFPA 70 National Electrical Code, OSHA and State and Local codes.

The inverter unit shall be IOTA model IIS 375 I.

\*20% de-rating required for LED applications

## TYPICAL WIRING

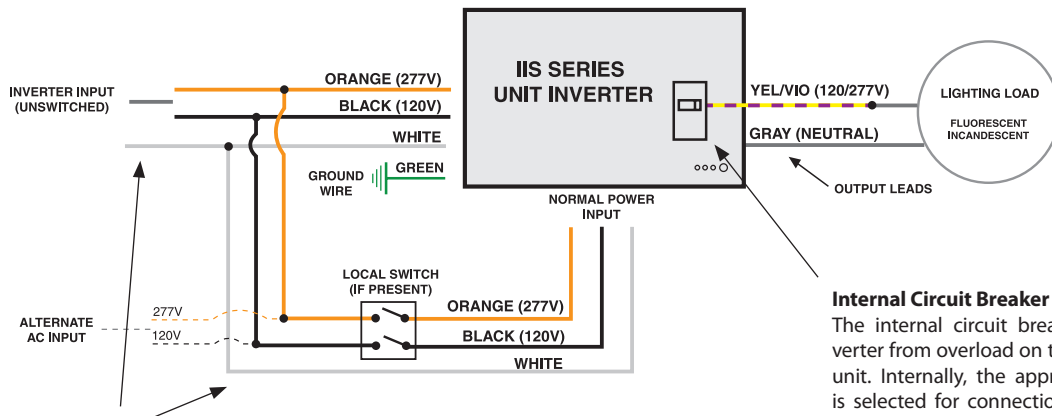

### Input Leads

The IIS Inverter utilizes two sets of input leads: one to provide unswitched power to the inverter system and a second to serve as a normal power input to the lighting load. Any switch for the designated emergency circuit will be present on the Normal Power Input leads. For Emergency Operation Only applications, the Normal Input leads are not needed and would remain disconnected and capped.

### Internal Circuit Breaker

The internal circuit breaker protects the inverter from overload on the output side of the unit. Internally, the appropriate voltage lead is selected for connection to the line side of the circuit breaker and the designated emergency load connects to the single Yellow/Violet 120/277V hot lead.

**Warranty:** 3-Year Limited Warranty

Complete warranty terms located at [www.acuitybrands.com/CustomerResources/Terms\\_and\\_conditions.aspx](http://www.acuitybrands.com/CustomerResources/Terms_and_conditions.aspx)