

INSTALLATION INSTRUCTIONS

F7 JOINING

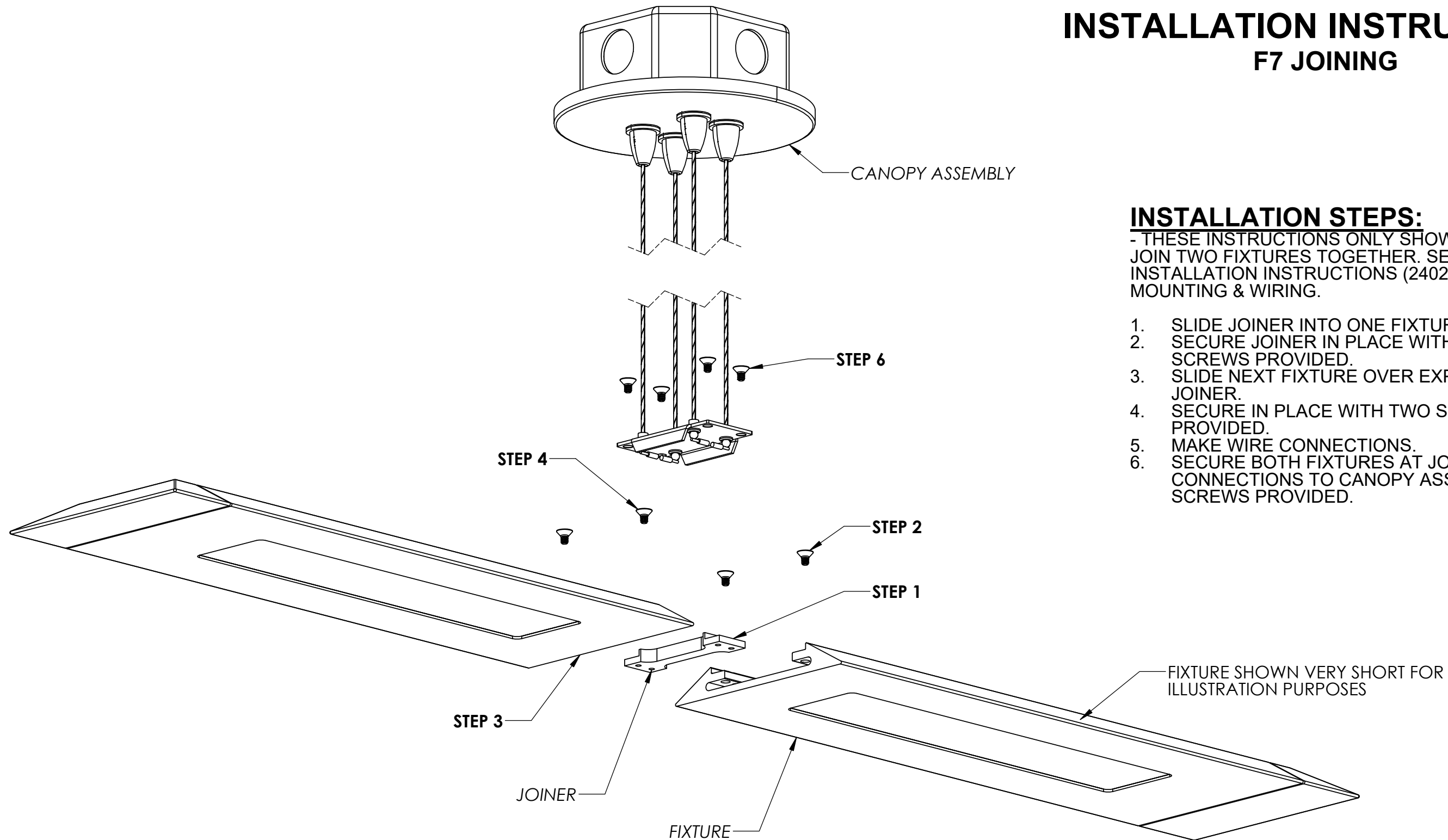

INSTALLATION STEPS:

- THESE INSTRUCTIONS ONLY SHOW HOW TO JOIN TWO FIXTURES TOGETHER. SEE MAIN INSTALLATION INSTRUCTIONS (2402863) FOR MOUNTING & WIRING.

1. SLIDE JOINER INTO ONE FIXTURE END.
2. SECURE JOINER IN PLACE WITH TWO SCREWS PROVIDED.
3. SLIDE NEXT FIXTURE OVER EXPOSED END OF JOINER.
4. SECURE IN PLACE WITH TWO SCREWS PROVIDED.
5. MAKE WIRE CONNECTIONS.
6. SECURE BOTH FIXTURES AT JOINED CONNECTIONS TO CANOPY ASSEMBLY WITH SCREWS PROVIDED.

TOOLS REQUIRED:

- 1) 5/64" HEX DRIVER
- 2) PHILIPS #2 DRIVER

 3760 West Fourth Street PO Box 1205 Winona, MN 55987 PH: (800) 328-5291 FAX: (507) 452-8528 www.winonalighting.com	DESCRIPTION: F7 INSTALLATION FIXTURE JOINING		PROJECT:	
	PART #: 2402864		SOLD TO:	
	DEPT:	ORDER #:	QTY:	FINISH:
	MATERIAL:	CLASS:	REV:	SCALE: 1:8
METHOD:	AUTHOR:	DATE:		
TOLERANCE UNLESS OTHERWISE SPECIFIED .X ± .XX ± .XXX ±		ANGLES ±		ALL DIMENSIONS ARE IN INCHES UNLESS SPECIFIED OTHERWISE
			SHEET #	1 OF 1