

PROPOSED T-GRID REMOTE DRIVER BOX INSTALLATION INSTRUCTIONS

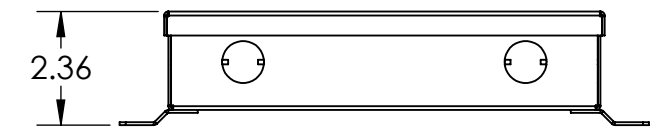

REMOTE 50W DRIVER BOX

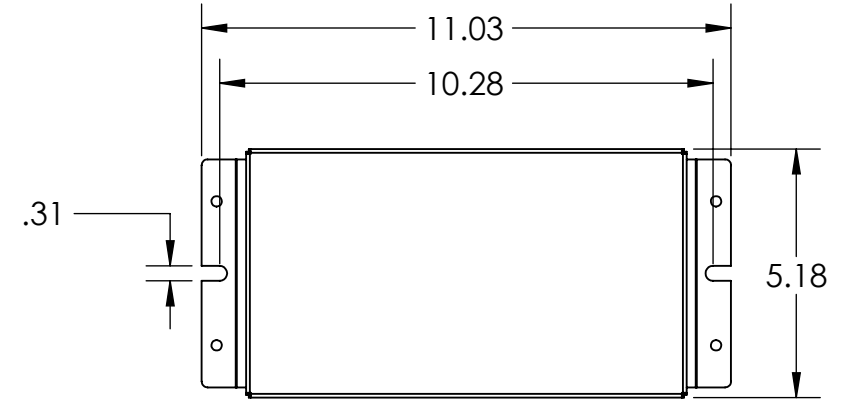
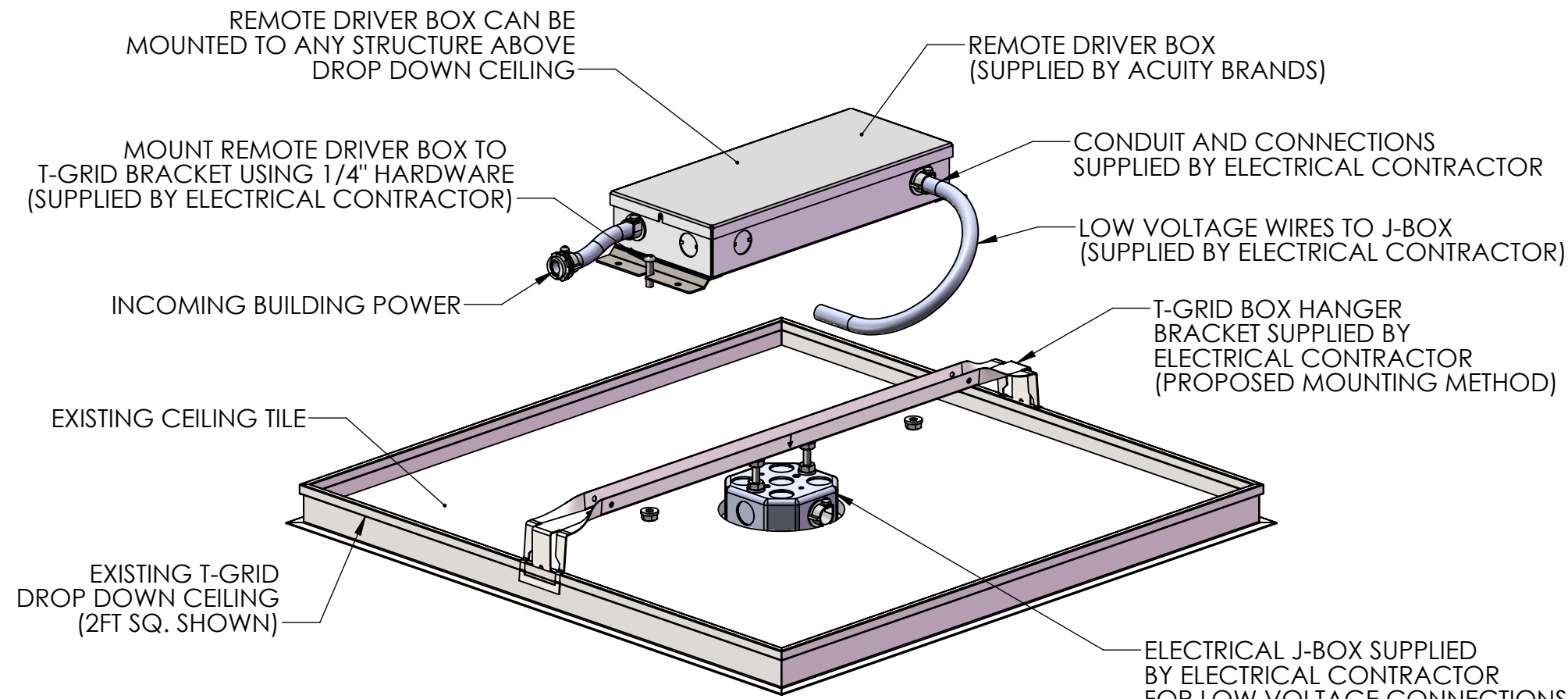
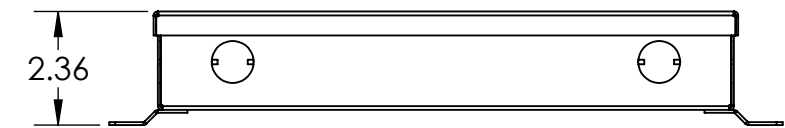
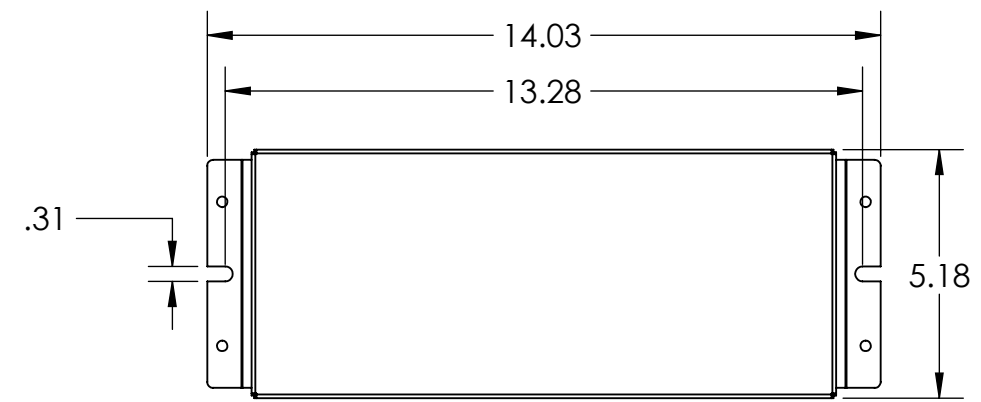

REMOTE 100W DRIVER BOX

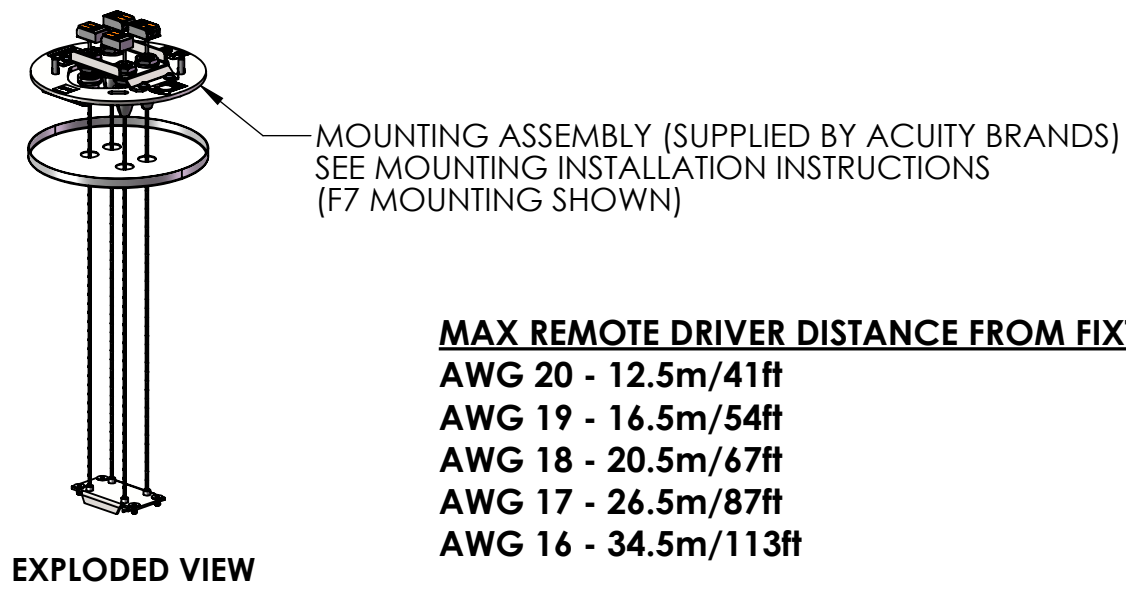

EXPLODED VIEW

- MAX REMOTE DRIVER DISTANCE FROM FIXTURE**
- AWG 20 - 12.5m/41ft
 - AWG 19 - 16.5m/54ft
 - AWG 18 - 20.5m/67ft
 - AWG 17 - 26.5m/87ft
 - AWG 16 - 34.5m/113ft

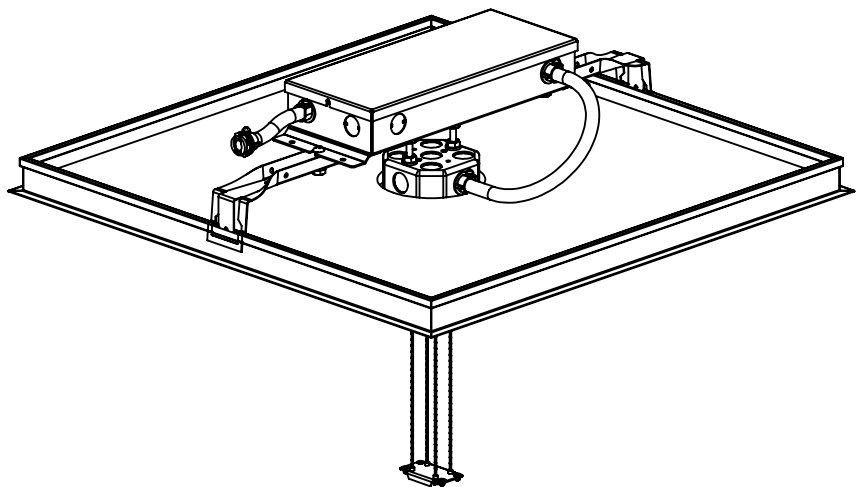

INSTALLED VIEW

<p>3760 West Fourth Street PO Box 1205 Winona, MN 55987 PH: (800) 328-5291 FAX: (507) 452-8528 www.winonalighting.com</p>	DESCRIPTION: T-GRID REMOTE DRIVER INSTALL		PROJECT: OLESSENCE	
	PART #:		SOLD TO:	
	DEPT:		ORDER #:	QTY:
	MATERIAL:		CLASS:	REV:
	METHOD:		AUTHOR: CWB01	DATE:
TOLERANCE UNLESS OTHERWISE SPECIFIED .X ± .XX ± .XXX ±		ANGLES ±		ALL DIMENSIONS ARE IN INCHES UNLESS SPECIFIED OTHERWISE SHEET # 1 OF 1