

FEATURES & SPECIFICATIONS

INTENDED USE — Ideal for wet location areas requiring combination exit sign and emergency lighting that are subject to saturation with non-mechanically delivered water.

CONSTRUCTION — White, compact, contemporary design. Housing also available in black. Engineering-grade thermoplastic housing is impact-resistant, scratch-resistant and corrosion-proof. Universal directional Chevron inserts are easily removed and reinserted. UL94V-0 flame rating. UV-stable resin resists discoloration from natural and man-made light sources. Rugged, heavy-duty, polycarbonate clear housing lens.

OPTICS — Low energy consumption — fewer than 5 watts. The typical life of the exit LED lamp is 5 years, based on 24/7 operation.

CRI: 77

CCT: 5000 K

ELECTRICAL — Dual voltage input capacity (120/277V).

Battery: — Sealed, maintenance free nickel-cadmium battery delivers 90 minutes rated capacity. Magnetic test switch (magnet included) provides manual activation of 30-second diagnostic testing for on-demand visual inspection.

Self-diagnostic testing (SD Option Only) for 30 seconds every 30 days, 30 minutes every 180 days and a 90-minute annual test. Diagnostic evaluation of LED light source, charging and battery condition.

INSTALLATION — Universal (top, end or back mount), canopy included. Junction box hole pattern for 4" octagon mounting. Flexible conduit entry.

LISTINGS — UL listed. Wet location listed. Standard temperature rating 32-122°F (0-50°C), CW (cold weather) temperature rating -4°F to 122°F (-20°C to 50°C). Meets UL 924, NFPA 101 (current Life Safety Code) and NFPA 70-NEC, FCC Title 47, Part 15, Subpart B.

WARRANTY — 5-year limited warranty. (Battery is prorated). This is the only warranty provided and no other statements in this specification sheet create any warranty of any kind. All other express and implied warranties are disclaimed. Complete warranty terms located at: www.acuitybrands.com/support/warranty/terms-and-conditions

Note: Actual performance may differ as a result of end-user environment and application.

All values are design or typical values, measured under laboratory conditions at 25 °C.

Specifications subject to change without notice.

† Exit Signs Certified in the CA Title 20 Appliance Efficiency Database.

| |
|----------------|
| Catalog Number |
| Notes |
| Type |

LED Wet Location Emergency Light / Exit Combo

DELEON DLTLC



ORDERING INFORMATION

Lead times will vary depending on options selected. Consult with your sales representative.

Example: DLTLC 1 R SD

| Series | Housing Color | Number of Faces | Letter color | Options |
|------------------------------|---------------|-----------------|--------------|---|
| DLTLC LED Wet Location Combo | (Blank) White | 1 Single Face | R Red | SD Self-Diagnostics |
| | B Black | 2 Double Face | G Green | TPS Tamperproof Screw Hardware CW Cold Weather |

DLTLC LED Wet Location Emergency Light / Exit Combo

SPECIFICATIONS

| EXIT/UNIT COMBO | Electrical Primary Circuit ¹ | | | |
|-----------------|---|------|----------------|-------|
| | Input Watts (W) | | Input Amps (A) | |
| | 120V | 277V | 120V | 277V |
| DLTLC | 5.7 | 5.7 | 0.057 | 0.024 |
| DLTLC CW | 5.7 | 5.7 | 0.057 | 0.024 |
| DLTLC SD | 7 | 7 | 0.063 | 0.03 |
| DLTLC TPS | 5.7 | 5.7 | 0.057 | 0.024 |
| DLTLC SD CW | 7 | 7 | 0.063 | 0.03 |
| DLTLC TPS CW | 5.7 | 5.7 | 0.057 | 0.024 |
| DLTLC SD TPS CW | 7 | 7 | 0.063 | 0.03 |

| EXIT | Electrical Primary Circuit ¹ | | | |
|----------------|---|------|-----------------|-------|
| | Input Watts (W)* | | Input Amps (A)* | |
| | 120V | 277V | 120V | 277V |
| DLTLC RED | 1.7 | 1.7 | 0.039 | 0.017 |
| DLTLC GREEN | 1.7 | 1.8 | 0.038 | 0.017 |
| DLTLC RED SD | 2.3 | 2.3 | 0.038 | 0.017 |
| DLTLC GREEN SD | 2.0 | 2.2 | 0.039 | 0.017 |

* Same electrical data when ordering CW option

BATTERY

| Ni-Cad | | | | | |
|---------|---------|---------------------------------|---------------------------|--------------------------|----------------------------------|
| Voltage | Options | Typical Shelf life ² | Typical life ² | Maintenance ³ | Temperature range ^{4,5} |
| 6V | STD | 3 years | 6-8 years | none | 32-122°F (0-50°C) |
| | CW | | | | -4°F to 122°F (-20°C to 50°C) |

- Based on 24/7 operation. The typical life of the exit LED lamp is 5 years.
- At 77°F (25°C).
- All life safety equipment, including emergency lighting path of egress, must be maintained, serviced and tested in accordance with all National Fire Protection Association and local codes. Failure to perform the required maintenance, service or testing could jeopardize the safety of occupants and will void all warranties.
- Optimum ambient temperature range where unit will provide capacity for 90 minutes. Higher and lower temperatures affect life and capacity.
- Battery life is negatively impacted by many variables including temperature, charging rates, number of cycles and deep discharges due to long periods of time without AC power.

MOUNTING

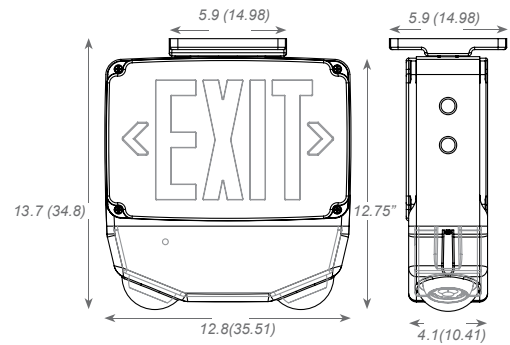

Specifications

Length: 12-3/8"
 Depth: 5-15/16"
 Height: 13-11/16"

All dimensions are inches (centimeters) unless otherwise indicated.

LAMP PHOTOMETRICS

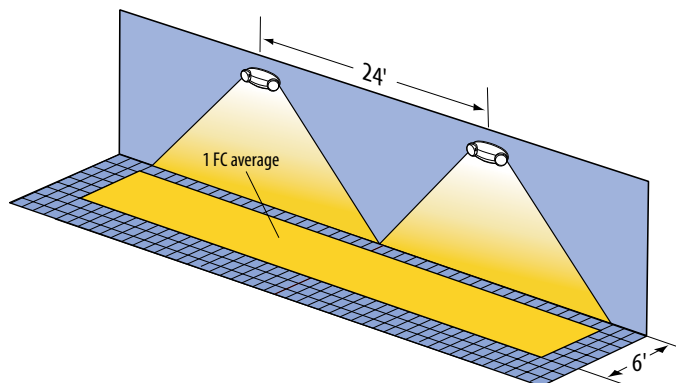

Example of multiple DLTLC exit/unit combos illuminating a 6' path of egress