

SLOT 6

RECESSED
DC2DC ARCHITECTURE

HIGHLIGHTS

- 300 to 1000 lumens per foot Direct
- Two lens depths: OD (Flush) and 1D (1" Regress)
- 3 direct distributions: Lambertian, Batwing, or Asymmetric
- Two lens treatment options: Continuous and Flush
- Driver option for Dim to Dark
- White, black or silver paint with satin finish
- UGR data available on page 4.



FIXTURE PERFORMANCE

Nominal Lumens/Foot	Direct*				
	300LMF	400LMF	600LMF	800LMF	1000LMF
Delivered Lumens/Foot	288	384	575	755	930
DC Input Watts/Foot**	2.40	3.16	4.68	6.30	7.90
Lumens/Watt	120	122	123	120	118

*Based on a 4FT 90CRI 35K fixture with 0" depth lens regress (OD), standard lambertian distribution, and flush lens (FLL)

**Standard photometry based on AC wattage, DC wattage = AC wattage * .93.

Note: See page 6 for Device Addresses and Feed details.



DIRECT DISTRIBUTION

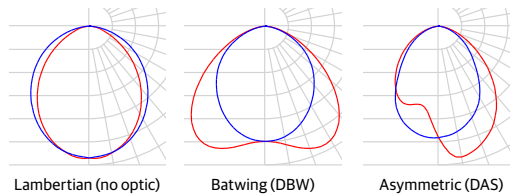

DIMENSIONS

Section View

FL Trim with OD Lens Regress

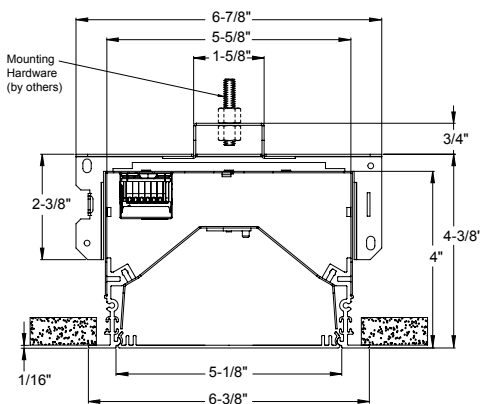

DIFFUSERS/SHIELDING

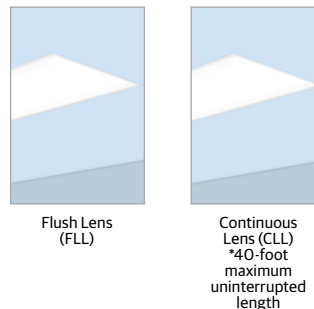

ORDERING

Example: S6RD LOP 24FT OD FL 90CRI 40K 100LMF SCT DARK CLL 57VDC SLVT 1EC DALI NS8 SNS16

--	--	--	--	--	--	--

Series	Linear Plan	Total Run Length	Lens Regress Depth	Ceiling Type	Direct Light Source Color Rendering	Direct LED Color Temperature
S6RD Slot 6 Recessed Direct	LOP Optimized Length	_FT_ Specify continuous linear feet to nearest 1/8" increments starting at 2FT (Example 24' - 6 1/8" = 24FT6.125) Unit length may affect available options. For runs longer than 8FT: ALWAYS order the run by the TOTAL RUN LENGTH. Ordering these sections individually will not provide the correct joining hardware to allow run connections in the field. 1. Use whole foot increment when using zoning option.	OD 0" Depth 1D^{1,2,3} 1" Depth 1. Available with FLL or CLL Optional Shielding only. 2. Not available with Direct Distribution options. 3. Not available with FLINB or GBINB	FL 5/8IN Flange (sheetrock) GB Gypsum Board (sheetrock) FLINB 5/8IN Flange (sheetrock) Install From Below GBINB Gypsum Board (sheetrock) Install From Below TG Grid Ceiling: 9/16" Flat Tee with Lay-In Tile, 9/16" Flat Tee with Tegular Tile, 9/16" Slot Tee with Tegular Tile, 15/16" Flat Tee with Lay-In Tile, & 15/16" Flat Tee with Tegular Tile FLW¹ 5/8IN Flange (sheetrock) Wall Mounted GBW¹ Gypsum Board (sheetrock) Wall Mounted 1. When using FLW or GBW options, FLW will change to FL & GBW will change to GB for shipping lines to designate same fixture as ceiling mounted units. *For compatibility with metal pans, hardwood, or other ceiling types, consult technical support.	90CRI 90CRI	27K 2700K 30K 3000K 35K 3500K 40K 4000K 50K 5000K

--	--	--	--	--	--

Direct LED Light Output	Direct Distribution ¹	Switching	Minimum Dimming Level	Optional Shielding	Voltage
300LMF 300 Lumens per Foot 400LMF 400 Lumens per Foot 600LMF 600 Lumens per Foot 800LMF 800 Lumens per Foot 1000LMF 1,000 Lumens per Foot _LMF Specify Lumens between 300LMF and 1000LMF in 50LMF increments.	<blank> Lambertian DAS Direct asymmetric distribution DBW Direct Batwing Distribution 1. Direct Distribution options are only available with FLL Direct Shielding and OD Lens Regress Depth option.	SCT Single Circuit	DARK Constant Current, Dimming to 0.1%	CLL^{1,3} Continuous Flush Lens FLL² Flush Lens 1. CLL is not available with DAS or DBW distributions. 2. When using distribution options, FLL will change to FLLC to designate a co-extruded lens with white and clear material. 3. 40-foot maximum uninterrupted length.	57VDC 57VDC, Class 2 Only

--	--	--	--	--	--

Finish	Emergency Options	Control Input	Primary Zone	Secondary Zone	Tertiary Zone Indicator
WHTT White (Satin) AMF Antimicrobial White BLKT Black (Satin) SLVT Silver (Satin) RALTB¹ RAL Paint Finish 1. RALTB ¹ is for pricing only. Replace with applicable RAL number & sheen when placing order	<blank> No Emergency Option _EC Total Number of Emergency Circuits	DALI eldoLED Driver DT6	<blank> No Sensor or Primary Zone Option NS_ Primary Zone with No Sensor (Specify zone length in feet.)	<blank> No Sensor or Secondary Zone Option SNS_ Secondary Zone with No Sensor (Specify zone length in feet.)	<blank> No Tertiary Zone TNS_ Tertiary Zone (Specify zone length in feet.)

--

Options

<blank> No Options
CP Chicago Plenum

PHOTOMETRICS

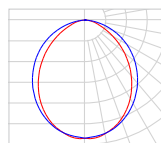

Test Report: ISF25 000770P2573
IES LM79-08
Catalog #: S6RD 4FT OD 90CRI 35K
1000LMF STD FLL
Lumens: 3718
DC Wattage:31.62
Efficacy: 117.57

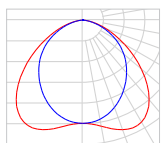

Test Report: ISF25 036529P363
IES LM79-08
Catalog #: S6RD 4FT OD 90CRI 35K
1000LMF DBW FLLC
Lumens: 3803
DC Wattage:31.62
Efficacy: 120.27

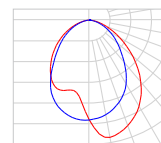

Test Report: ISF25 024633P1378
IES LM79-08
Catalog #: S6RD 4FT OD 90CRI 35K
1000LMF DAS FLLC
Lumens: 4041
DC Wattage:31.62
Efficacy: 127.80

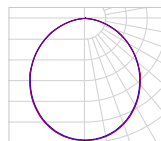

Test Report: ISF25 024629P1348
IES LM79-08
Catalog #: S6RD 4FT OD 90CRI 35K
1000LMF STD CLL
Lumens: 3685
DC Wattage:31.62
Efficacy: 116.53

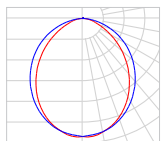

Test Report: ISF25 000770P1136
IES LM79-08
Catalog #: S6RD 4FT ID 90CRI 35K
1000LMF STD FLL
Lumens: 3510
DC Wattage:31.62
Efficacy: 111.01

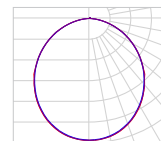

Test Report: ISF25 024629P363
IES LM79-08
Catalog #: S6RD 4FT ID 90CRI 35K
1000LMF STD CLL
Lumens: 3479
DC Wattage:31.62
Efficacy: 110.03

PROJECT LED LUMEN MAINTENANCE

Data references the extrapolated performance projections for the platforms noted in a 25°C ambient, based on 10,000 hours of LED testing (tested per IESNA LM-80-08 and projected per IESNA TM-21-11).

To calculate LLF, use the lumen maintenance factor that corresponds to the desired number of operating hours below. For other lumen maintenance values, contact factory.

Operating Hours	0	10,000	60,000	100,000
Lumen Maintenance Factor	1	0.98	0.84	0.75

CCT SCALING CHART

CCT	CRI	MULTIPLIER	R9
27K	90CRI	0.9444	54.61
30K	90CRI	0.9722	69.01
35K	90CRI	1.0000	83.41
40K	90CRI	1.0278	91.19
50K	90CRI	1.0278	90.86

Lumen scaling charts can be used to approximate the lumen values at different Kelvin temperatures, color rendering indices, optics, or shielding.

Example: Calculating the lumen change from 90CRI 35K to 90CRI 40K = Lumen output for S6RD 4FT OD 90CRI 35K 1000LMF FLL (3718) x 1.0278 multiplier = 3821 lumen

OPTICAL SCALING CHARTS

DISTRIBUTIONS	MULTIPLIER
LAMBERTIAN	1.00
DBW	0.99
DAS	1.09
SHIELDING	MULTIPLIER
CLL	0.99
FLL	1.00

*Base fixture with Lambertian distribution and flush lens (FLL)

50LMF INCREMENT SCALING CHART

NOMINAL LMF	LUMEN	WATTAGE
	MULTIPLIER	MULTIPLIER
300LMF	0.31	0.30
350LMF	0.36	0.35
400LMF	0.41	0.40
450LMF	0.46	0.45
500LMF	0.52	0.50
550LMF	0.57	0.54
600LMF	0.62	0.59
650LMF	0.67	0.64
700LMF	0.72	0.69
750LMF	0.76	0.75
800LMF	0.81	0.80
850LMF	0.86	0.85
900LMF	0.91	0.90
950LMF	0.96	0.95
1000LMF	1.00	1.00

*Base fixture with 0" depth lens regress (OD), standard lambertian distribution, flush lens (FLL), and 1000LMF

REGRESS DEPTH SCALING CHART

LENS REGRESS DEPTH	MULTIPLIER
OD	1.00
1D	0.94

*Base fixture with Lambertian distribution, 0" depth lens regress (OD), and flush lens (FLL)

UGR CHART

Lumen Package	UGR (70% 50% 20% reflectance using a 4H x 8H room size)					
	Crosswise					
	OD FLL Lambertian	OD CLL Lambertian	OD DBW	OD DAS	1D FLL Lambertian	1D CLL Lambertian
300LMF	19.3	19.3	17.4	16.8	19.1	19.1
400LMF	20.3	20.3	18.4	17.8	20.1	20.1
600LMF	21.7	21.7	19.8	19.2	21.5	21.5
800LMF	22.6	22.7	20.7	20.2	22.4	22.5
1000LMF	23.4	23.4	21.5	20.9	23.2	23.2
	Endwise					
	OD FLL Lambertian	OD CLL Lambertian	OD DBW	OD DAS	1D FLL Lambertian	1D CLL Lambertian
	300LMF	16.7	18.9	18.5	18.5	16.5
400LMF	17.7	19.9	19.4	19.5	17.5	19.7
600LMF	19.1	21.3	20.9	20.9	18.9	21.1
800LMF	20	22.3	21.8	21.9	19.8	22.1
1000LMF	20.8	23	22.5	22.6	20.6	22.8

*UGR varies based on luminaire options and is affected by application dependent parameters. Numbers depicted here are considered "Luminaire-UGR" and/or "Point-UGR" values. To determine a more precise maximum UGR value ("Application-UGR"), a full lighting design layout should be completed with the selected luminaire configuration for each application.

**Click here for more information on: [UGR FAQ](#)

CEILING TRIMS

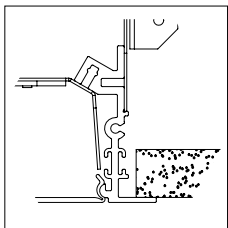

FL
5/8IN Flange (sheetrock)
Install Before Sheetrock

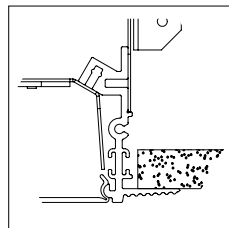

GB
Gypsum Board (sheetrock)
Install Before Sheetrock

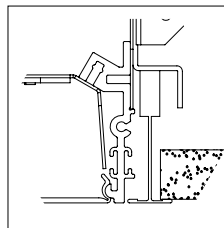

TG
9/16" Flat Tee w/ Lay-in Tile

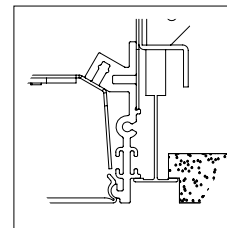

TG
9/16" Flat Tee w/ Tegular Tile

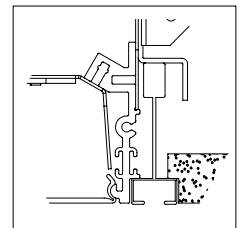

TG
9/16" Slot Tee w/ Tegular Tile

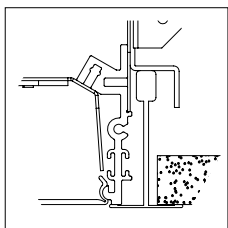

TG
15/16" Flat Tee w/ Lay-in Tile

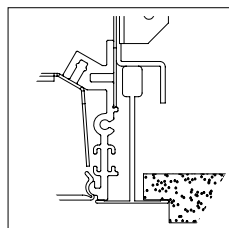

TG
15/16" Flat Tee w/ Tegular Tile

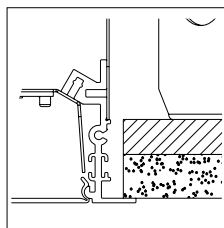

FLNB
5/8IN Flange (sheetrock)
Install From Below

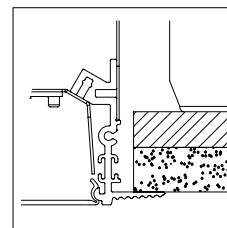

GBNB
Gypsum Board (sheetrock)
Install From Below

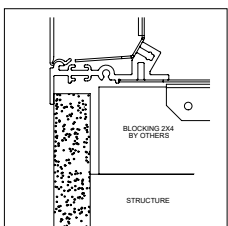

FLW
5/8IN Flange (sheetrock)
Wall Mounted

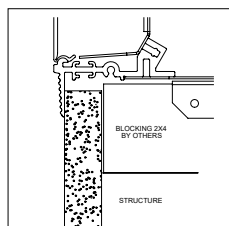

GBW
Gypsum Board (sheetrock)
Wall Mounted

*For compatibility with metal pans, hardwood, or other ceiling types, consult technical support.
*TG ceiling trim types are compatible with Armstrong 6" TECHZONE ceiling grid.

INTELLIGENT LUMINAIRE GUIDE

Choose nomenclature from these columns

Driver Configurations	Minimum Dimming Level	Control Input	Driver	Dimming Range	Notes
	DARK	DALI	eldoLED SOLOdrive DC Driver - Dali 2 compatible with Device Type 6 (DT6) functionality	100% to 0.1%	Logarithmic Dimming

LINEAR PLAN

Mark Lighting calculates a continuous run based on optimizing fixture section length and options selected.

LOP- Linear Optimized Length

This linear plan supplies the run length based on defined length combinations, resulting in an optimized LOP solution with the fewest segments.

8FT	4FT	3FT
-----	-----	-----

Total Run Length

This system is not modular. Runs longer than 8FT will be automatically configured with left, intermediate, and right sections based on nomenclature ordered. Always order the total run length required and not individual sections.

Example: This run to be ordered as one 32FT run.

8FT	8FT	8FT	8FT
-----	-----	-----	-----

Example: This run to be ordered as four 8FT runs. Note: Individual fixtures sections cannot be joined together in the field.

8FT	8FT	8FT	8FT
-----	-----	-----	-----

MOUNTING

FL and GB Trim Run

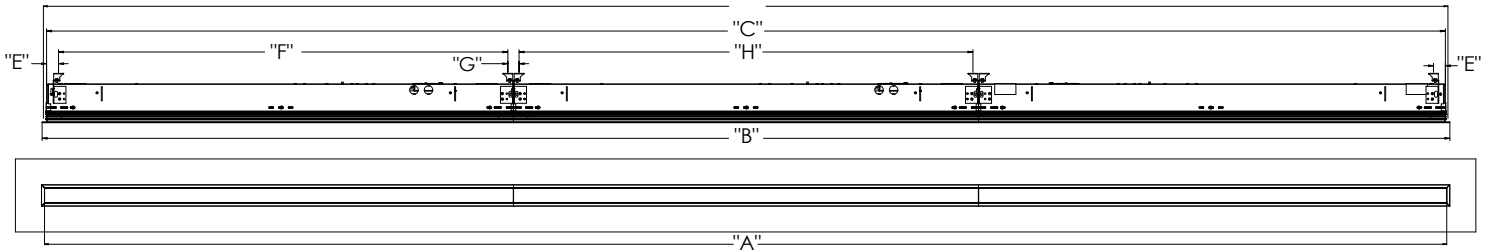

FL Run Configurations							
"A" (Illuminated Length)	"B" (Trim Length)	"C" (Housing Length)	"D" (Cut Opening Length)	"E" (End Mounting Location)	"F" (End Fixture Middle Mounting Point)	"G" (Mounting Point to Mounting Point)	"H" (Mounting Point to Mounting Point Intermediate Fixtures)
Order Length	Ordered Length + 15/16" (FL) + 113/16" (GB)	Order length + 9/16"	Order length + 13/16"	1 1/4"	Fixture length - 1 1/2"	1 1/16"	Fixture length - 1 1/16"

TG Trim Run

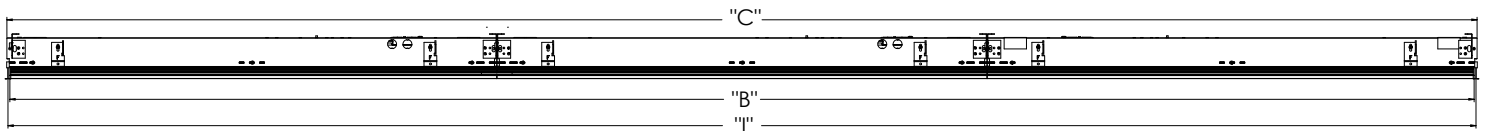

Grid Run Configurations			
"A" (Illuminated Length)	"B" (Trim Length)	"C" (Housing Length)	"I" (Grid Center to Center)
Order length - 13/16"	Ordered Length - 5/8"	Order length - 1/32"	Order length + 13/16"

MOUNTING (continued)

FLINB and GBINB Trim Run

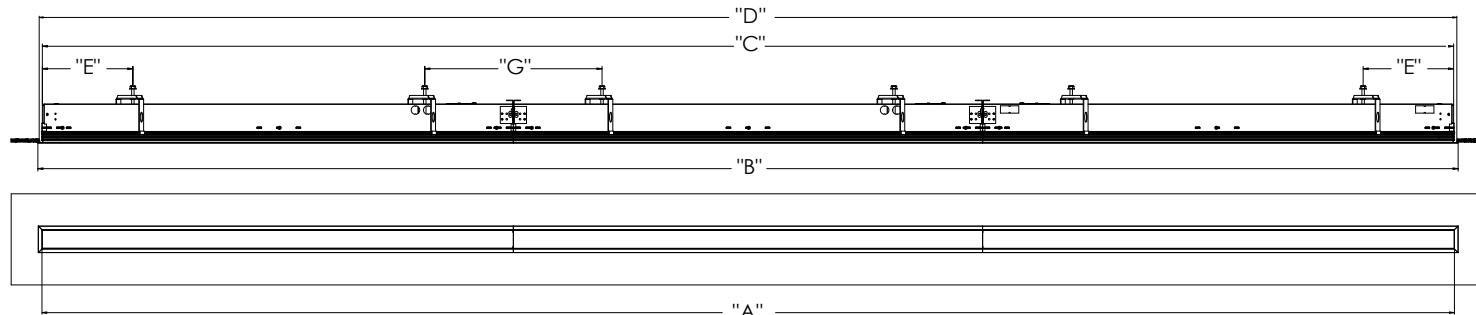

FL Run Configurations					
"A" (Illuminated Length)	"B" (Trim Length)	"C" (Housing Length)	"D" (Cut Opening Length)	"E" (End Mounting Location)	"G" (Mounting Point to Mounting Point)
Order Length	Order Length + 1 5/16"(FLINB) + 1 13/16"(GBINB)	Order length +9/16"	Order length +13/16"	6 1/4" 9 1/4"	1' 0 1/2" 1' 3 1/2" 1' 6 1/2"

NOTE: Dimension "E" depends on length (inconsistent across family). **NOTE:** Dimension "G" depends on fixture combination.

Ceiling Cut Out Dimensions

		2-Foot	3-Foot	4-Foot	5-Foot	6-Foot	7-Foot	8-Foot
TG	GRID CL LENGTH(IN)	24	36	48	60	72	84	96
	GRID CL WIDTH(IN)	6	6	6	6	6	6	6
FL or FLINB	LENGTH(IN)	24.813	36.813	48.81	60.813	72.813	84.81	96.813
	WIDTH(IN)	5.885	5.885	5.89	5.885	5.885	5.89	5.885
GB or GBINB	LENGTH(IN)	24.813	36.813	48.81	60.813	72.813	84.81	96.813
	WIDTH(IN)	5.885	5.885	5.89	5.885	5.885	5.89	5.885

CEILING OPENING DIMENSIONS FOR INSTALLATION, +/-0.13"

MOUNTING (continued)

FIXTURE DIMENSIONS AND WEIGHTS

		2-Foot	3-Foot	4-Foot	5-Foot	6-Foot	7-Foot	8-Foot	
		Individual	GRID CL (IN)	24	36	48	60	72	84
TG	Individual	OVERALL LENGTH (IN)	23.375	35.375	47.375	59.375	71.375	83.375	95.375
		HOUSING LENGTH (IN)	23.938	35.938	47.938	59.938	71.938	83.938	95.938
		APERTURE (IN)	23.125	35.125	47.125	59.125	71.125	83.128	95.125
	Left or Right	2-Foot	3-Foot	4-Foot	5-Foot	6-Foot	7-Foot	8-Foot	
		GRID CL(IN)	24	36	48	60	72	84	96
		PRODUCT LENGTH(IN)	23.688	35.688	47.688	59.688	71.688	83.688	95.688
		HOUSING LENGTH(IN)	23.938	35.938	47.938	59.938	71.938	83.938	95.938
	Intermediate	APERTURE(IN)	23.563	35.563	47.563	59.563	71.563	83.563	95.563
		2-Foot	3-Foot	4-Foot	5-Foot	6-Foot	7-Foot	8-Foot	
		GRID CL(IN)	24	36	48	60	72	84	96
Left or Right	PRODUCT LENGTH(IN)	24	36	48	60	72	84	96	
	HOUSING LENGTH(IN)	23.938	35.938	47.938	59.938	71.938	83.938	95.938	
	APERTURE(IN)	24	36	48	60	72	84	96	
Intermediate	2-Foot	3-Foot	4-Foot	5-Foot	6-Foot	7-Foot	8-Foot		
	GRID CL(IN)	24	36	48	60	72	84	96	
	PRODUCT LENGTH(IN)	24	36	48	60	72	84	96	
	HOUSING LENGTH(IN)	23.938	35.938	47.938	59.938	71.938	83.938	95.938	
Left or Right	APERTURE(IN)	24	36	48	60	72	84	96	
	PRODUCT LENGTH(IN)	24	36	48	60	72	84	96	
	HOUSING LENGTH(IN)	23.938	35.938	47.938	59.938	71.938	83.938	95.938	

		2-Foot	3-Foot	4-Foot	5-Foot	6-Foot	7-Foot	8-Foot	
		Individual	APERTURE(IN)	24	36	48	60	72	84
FL or FLINB	Individual	PRODUCT LENGTH(IN)	25.250	37.250	49.250	61.250	73.250	85.250	97.250
		HOUSING LENGTH(IN)	24.563	36.563	48.563	60.563	72.563	84.563	96.563
	Left or Right	2-Foot	3-Foot	4-Foot	5-Foot	6-Foot	7-Foot	8-Foot	
		APERTURE(IN)	24	36	48	60	72	84	96
		PRODUCT LENGTH(IN)	24.625	36.625	48.625	60.625	72.625	84.625	96.625
	Intermediate	HOUSING LENGTH(IN)	24.250	36.250	48.250	60.250	72.250	84.250	96.250
		2-Foot	3-Foot	4-Foot	5-Foot	6-Foot	7-Foot	8-Foot	
	Left or Right	APERTURE(IN)	24	36	48	60	72	84	96
		PRODUCT LENGTH(IN)	24	36	48	60	72	84	96
		HOUSING LENGTH(IN)	23.938	35.938	47.938	59.938	71.938	83.938	95.938
Intermediate	APERTURE(IN)	24	36	48	60	72	84	96	
	PRODUCT LENGTH(IN)	24	36	48	60	72	84	96	
	HOUSING LENGTH(IN)	23.938	35.938	47.938	59.938	71.938	83.938	95.938	

		2-Foot	3-Foot	4-Foot	5-Foot	6-Foot	7-Foot	8-Foot	
		GB or GBINB	Individual	APERTURE(IN)	24	36	48	60	72
PRODUCT LENGTH(IN)	25.750			37.750	49.750	61.750	73.750	85.750	97.750
HOUSING LENGTH(IN)	24.563			36.563	48.563	60.563	72.563	84.563	96.563
Left or Right	2-Foot		3-Foot	4-Foot	5-Foot	6-Foot	7-Foot	8-Foot	
	APERTURE(IN)		24	36	48	60	72	84	96
	PRODUCT LENGTH(IN)		24.875	36.875	48.875	60.875	72.875	84.875	96.875
Intermediate	HOUSING LENGTH(IN)		24.250	36.250	48.250	60.250	72.250	84.250	96.250
	2-Foot		3-Foot	4-Foot	5-Foot	6-Foot	7-Foot	8-Foot	
Left or Right	APERTURE(IN)		24	36	48	60	72	84	96
	PRODUCT LENGTH(IN)		24	36	48	60	72	84	96
	HOUSING LENGTH(IN)		23.938	35.938	47.938	59.938	71.938	83.938	95.938
Intermediate	APERTURE(IN)	24	36	48	60	72	84	96	
	PRODUCT LENGTH(IN)	24	36	48	60	72	84	96	
	HOUSING LENGTH(IN)	23.938	35.938	47.938	59.938	71.938	83.938	95.938	

*All values rounded to +/- 1/16"

Approximate Fixture Section Weights	2-Foot	3-Foot	4-Foot	5-Foot	6-Foot	7-Foot	8-Foot
	WEIGHT(LBS)	12	15	18	27	30	33

DIRECT SHIELDING & OPTIONS

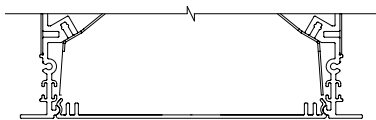

Flush Lens (FLL)
Continuous Lens (CLL)

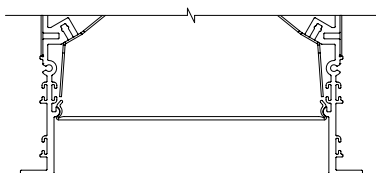

1" Regress with
FLL or CLL

DIRECT DISTRIBUTION

Optical Film for DAS and DBW distributions with co-extruded lens standard.
Direction of light for DAS distribution will be in the direction of the notches on the film.

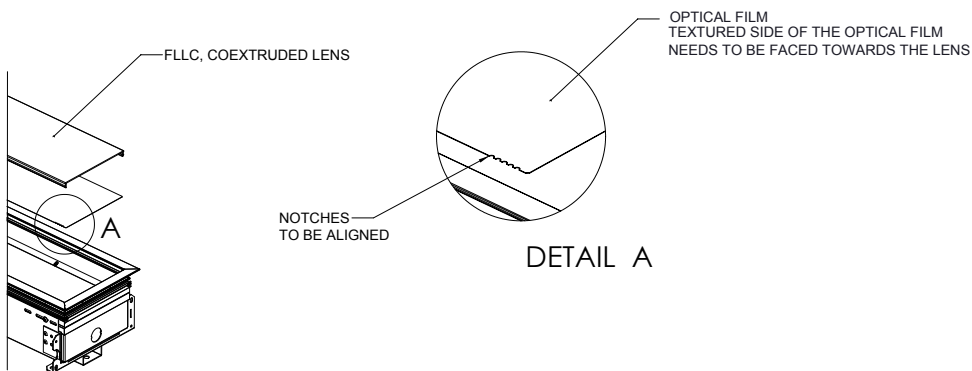

Optical Film	Number of Notches
Diffuser	4
Direct Asymmetric (DAS)	1
Direct Batwing (DBW)	2



When ordering distribution options, use FLL designation. FLL will automatically change to FLLC on shipped product, to designate this co-extruded lens with white and clear material.

CONTINUOUS LENS

40-foot maximum uninterrupted length. From 40-foot 1/8-inch to 106-foot, visible joiner required and supplied with lens rolls. Joiner will match color of trim. Continuous lens and joiners, if required, ship separate from the fixture. Reference installation instructions for further details and steps.

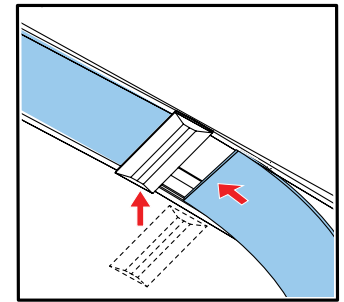
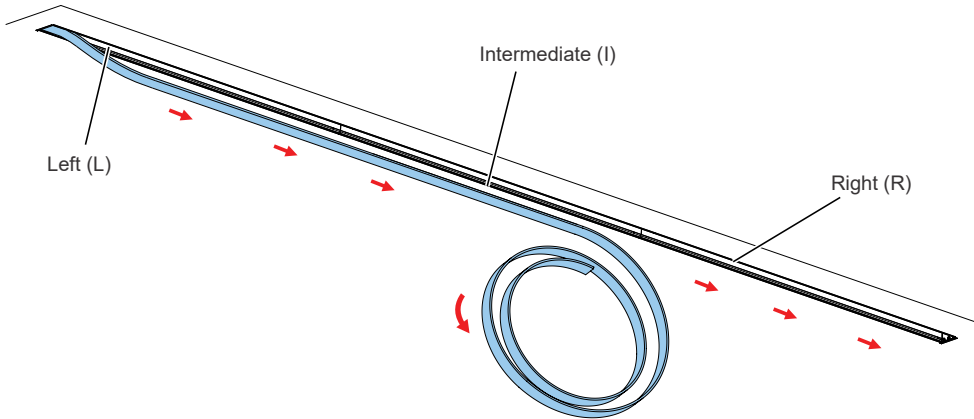

Continuous Lens Joiner Detail

RUN PATTERNS, CORNERS, & JUNCTIONS

Patterns can be configured in 1" increments with illuminated L (corner), X, Y, & T connectors. Standard corner has 2' leg segments. Standard L (corner) connector angles are available in 40-179 degrees in 1 degree increments. Standard T & Y connector angles are available in 40-179 degrees in 1 degree increments. Standard X connector angle available in 40-90 degrees in 1 degree increments.

See separate pattern spec sheet for more details.

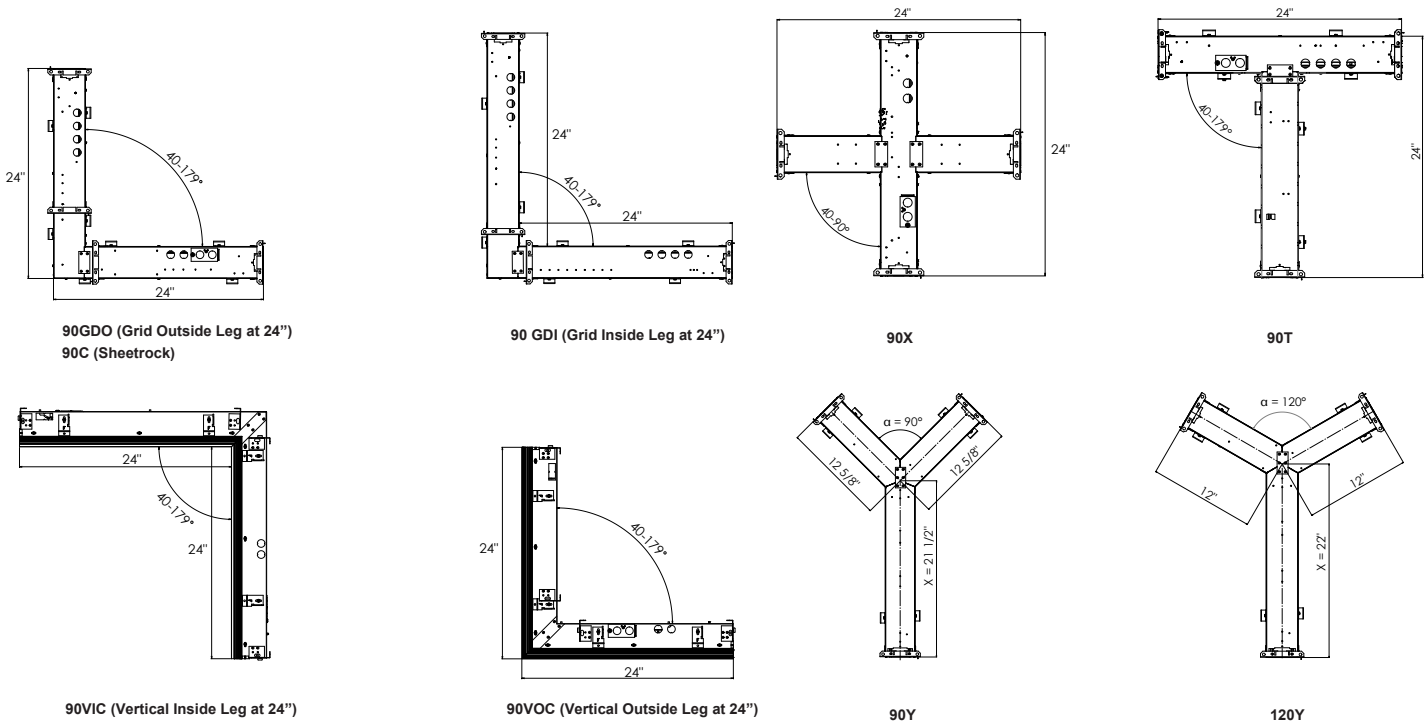

NOTE: For Y intersections, dimension X varies depending on the angle α . Angle α can be in a range of 40-179°.

EMERGENCY OPTIONS

Emergency Circuits

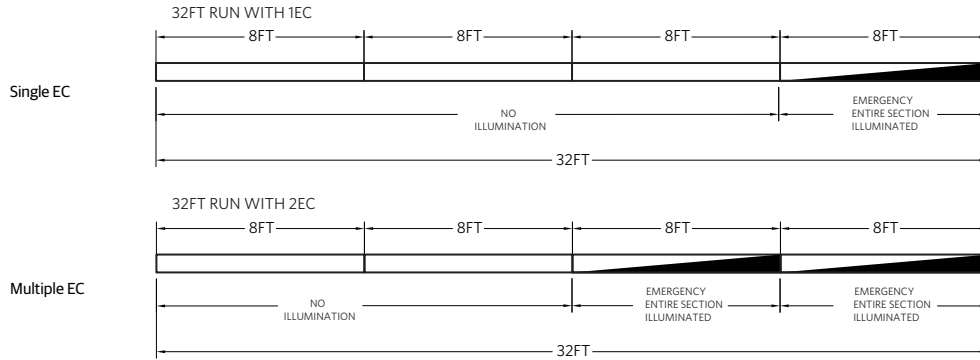

Control Input	
Section Length	EC
U2-U2/11.875	Entire Section Length
U3-U3/11.875	Entire Section Length
U4	Entire Section Length
U4/0.125-U4-11.875	Entire Section Length
U5-U5/11.875	Entire Section Length
U6-U6/11.875	Entire Section Length
U7-U7/11.875	Entire Section Length
U8	Entire Section Length

DC2DC

DC-powered Lighting, DC2DC Architecture

Acuity Brands' DC2DC architecture provides for distributed low-voltage DC power and digital controls for a range of LED luminaires, including the S6RD.

The DC2DC architecture enhances an LED lighting system's efficiency by eliminating the need and cost to convert AC to DC power at the luminaire and facilitating the installation and commissioning of lighting controls. Inherently more efficient by design, our DC-powered lighting architecture also delivers savings at design and installation, facilitates maintenance, and empowers lighting design focused on sustainable and well-being applications.

Components include:

- DCHUB (ordered separately), distributes DC power up to 1080 VA of DC-powered LED luminaires including support for emergency lighting.
- 57 VDC powered LED luminaires, with Static CCT or Tunable White, based on control options.
- nLight® lighting control
- Integral or offboard wired networked lighting control, with nLight control devices (ordered separately).
- Embedded nLight AIR wireless devices in 57VDC powered Static CCT LED luminaires.
- Class 2 power and control cables.
- The number of luminaires that can be supported by a single DCHUB port is a function of luminaire wattage and conductor losses. Please refer to the fixture wattages listed and the DCHUB spec sheet for additional details. Alternatively, the LED luminaires can be supplied with an approved, UL Listed, Class 2 power source supplying between 52.3 and 57.0 VDC at the input to the luminaire.

Note:

All luminaires require 57VDC option along with the corresponding Control Input option for DALI or DALI8 external nPS80 DALI 57VDC wired nLight control or NLTAIR2 or NLTAIREM2 embedded wireless lighting control.

When using external wired nLight control, nPS80 DALI 57 VDC is mounted locally with the controlled luminaires. Only 2 #16 AWG (min.) conductors are necessary between the DC power source and the nPS80 DALI controller, and 4 conductors between the controller and the luminaires.

When using nLight embedded wireless controls only 2 #16 AWG (min.) conductors are necessary between the DC power source and the luminaire runs.

Click [DC2DC](#) for more information.

FIXTURE PERFORMANCE, DEVICE ADDRESSES, & FEED CHART¹

		Slot 6 Recessed Direct ¹				
Nominal Lumens/Foot		300LMF	400LMF	600LMF	800LMF	1000LMF
Delivered Lumens/Foot		288	384	575	755	930
DC Input Watts/Foot ²		2.40	3.16	4.68	6.30	7.90
Lumens/Watt		123	125	125	120	122
# Device Addresses and Feeds	2FT	1	1	1	1	1
	3FT	1	1	1	1	1
	4FT	1	1	1	1	1
	5FT ³	2	2	2	2	2
	6FT ⁴	2	2	2	2	2
	7FT ⁵	2	2	2	2	2
	8FT ⁴	2	2	2	2	2

Notes

1. Based on a 4ft 90CRI 35K fixture with 0" depth lens regress (OD), standard lambertian distribution, and flush lens (FLL). Consult factory for other section lengths.
2. Standard photometry based on AC wattage, DC wattage = AC wattage * .93, add 0.2 watts per foot when adding NLTAIR2 controls
3. For 5ft fixtures with two feeds, wattage for Feed 1 is 3/5 of the total wattage and for Feed 2 is 2/5 of the total wattage
4. For 6ft and 8ft fixtures with two feeds, wattage per feed is half of the total wattage
5. For 7ft fixtures with two feeds, wattage for Feed 1 is 4/7 of the total wattage and for Feed 2 is 3/7 of the total wattage

General Note: Combine feeds based on maximum port supply wattage or as shown on drawings. Refer to Mark Linear Submittal drawings for additional feed configuration information.

Example Calculation:

8FT 1000LMF

Device Addresses and Feeds: 2 Addresses and Feeds
 Total Wattage: 7.90 W/FT x 8FT = 63.2W
 Feed 1: 4/8 x 63.2W = 31.6W
 Feed 2: 4/8 x 63.2W = 31.6W

SPECIFICATIONS

Housing

Nominal 6" x 2', 3', 4', 5', 6', 7', 8' and continuous rows in 1/8" increments starting at 2', as standard. Upper housing fabricated from cold-rolled steel with extruded aluminum ceiling trim.

Finish

Standard colors for fixture trims are polyester powder coated white, anti-microbial white, black, or silver with satin sheen. Consult factory for custom colors or specify RAL colors from Architectural brochure.

Reflector

Precision-formed steel; high reflectance matte white powder coat; 93% reflectivity.

Optics (Distribution)

Direct Batwing (DBW) and Direct Asymmetric (DAS) incorporate co-extruded lenses and films.

Lenses/Shielding

Extruded acrylic lens, (CLL, FLL).

Mounting

Sheetrock: Recessed ceiling only to accommodate sheetrock, 1/2" minimum to 1-1/2" maximum depth for FL, GB, FLINB or GBINB trim options. Grid: To accommodate 9/16" Flat Tee with Lay-In Tile, 9/16" Flat Tee with Tegular Tile, 9/16" Slot Tee with Tegular Tile, 15/16" Flat Tee with Lay-In Tile, & 15/16" Flat Tee with Tegular Tile.

LED Source

Multiple lumen packages available with 2700K, 3000K, 3500K, 4000K, and 5000K CCT in 90CRI. The Acuity Brands circuit boards for the linear LED components use a precise binning algorithm which creates a consistent color temperature from board to board. Color variation of no greater than a 2.5 Step MacAdam (2.55DECM) along the black body locus from board to board.

Electrical

Long-life LEDs, coupled with high-efficiency drivers, provide superior quantity and quality of illumination for extended service life. 90% LED lumen maintenance at 60,000 hours (L90/60,000).

Circuits

Single switching option only.

Dimming Driver

eldoLED constant current driver options deliver choice of dimming range for ultrasmooth dimming resolution from 100% to less than 1% , and choices for control, while assuring flicker free, low current inrush, 89% efficiency and low EMI. Luminaires operate over a voltage ranging from 53VDC to 57VDC.

Ambient Operating Temperature Range

-20°C (-4° F) to +25°C (+77°F)

Environment

Suitable for damp location. Indoor use only.

Certification

CSA certified to meet U.S. and Canadian standards (UL1598 and UL8750). This product is IC rated.

Fixture Weight

Approximately 6.0 lbs per foot, less packaging.

Warranty

5-year limited warranty. This is the only warranty provided and no other statements in this specification sheet create any warranty of any kind. All other express and implied warranties are disclaimed. Complete warranty terms located at: www.acuitybrands.com/support/warranty/terms-and-conditions

Notes: Actual performance may differ as a result of end-user environment and application.

All values are design or typical values, measured under laboratory conditions at 25 °C.

Specifications subject to change without notice