

TYPE:

PROJECT:

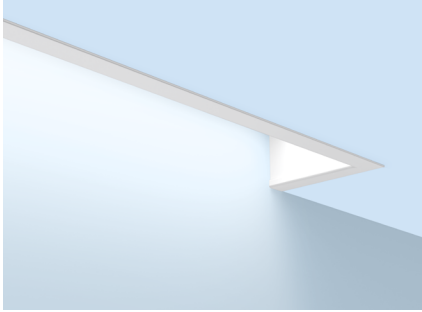

SLOT 2

PERIMETER
DYNAMIC RGBW

HIGHLIGHTS

- Compact profile
- Uniform illumination along wall surface
- Extruded aluminum and sheet metal construction
- Regressed snap-in acrylic lens
- DMX with Remote Device Management
- White, black or silver paint with satin finish



FIXTURE PERFORMANCE

RGBW	Direct				
	Red	Green	Blue	4000K	All Channels on 100%
Delivered Lumens/Foot	185	363	126	817	604
Input Watts/Foot	5.45	8.95	7.66	10.01	10.38
Lumens/Watt	34	41	16	82	58

Based on a 4FT 90CRI ARTC RGBW fixture with 2" depth lens regress (2D), standard lambertian distribution, and flush lens (FLL)



DIRECT DISTRIBUTION

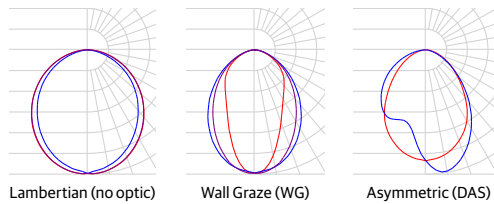

DIMENSIONS

FL Trim with 2D Lens Regress

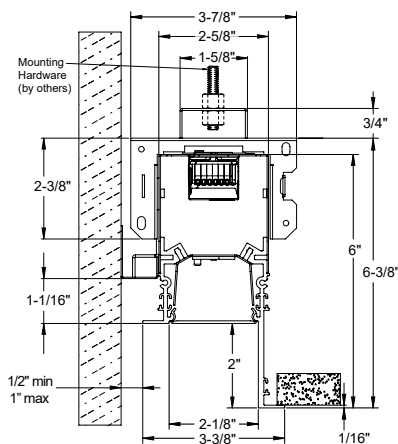

DIFFUSERS/SHIELDING

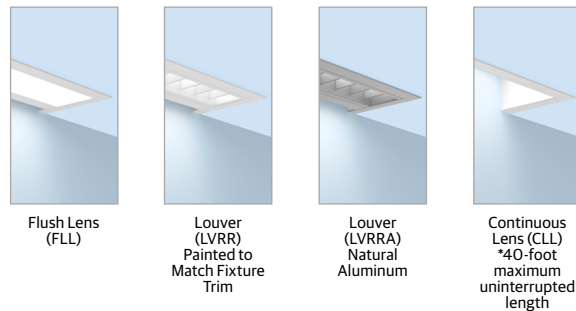

ORDERING

Example: S2CD LOP 27FT8.375 2D FL 90CRI ARTC RGBW 1000LMF SCT DARK FLL MVOLT BLKT DMX W2W

--	--	--	--	--	--

Series	Linear Plan	Total Run Length	Lens Regress Depth	Ceiling Type	Direct Light Source Color Rendering
S2CD Slot 2 Perimeter Direct	LOP Optimized Length	.FT Specify continuous linear feet to nearest 1/8" increments starting at 2FT (Example 24' - 6 1/8" = 24FT6.125) .FT' Specify continuous linear feet to whole foot increments starting at 2FT (Example: 24' = 24FT) Unit length may affect available options. For runs longer than 8FT: ALWAYS order the run by the TOTAL RUN LENGTH. Ordering the sections individually will not provide the correct joining hardware to allow run connections in the field. 1. Use whole foot increment when using LVRR or LVRRRA options.	OD 0" Depth 1D' 1" Depth 2D' 2" Depth 1. Not available with Direct Distribution options.	FL 5/8IN Flange (sheetrock) TG Grid Ceiling: 9/16" Flat Tee with Lay-In Tile, 9/16" Flat Tee with Tegular Tile, 9/16" Slot Tee with Tegular Tile, 15/16" Flat Tee with Lay-In Tile, & 15/16" Flat Tee with Tegular Tile	90CRI 90CRI

--	--	--	--	--	--

Direct Dynamic Feature	Direct Dynamic Range	Direct LED Light Output	Direct Distribution¹	Switching	Minimum Dimming Level
ARTC Architainment Color	RGBW Dynamic Color: Red, Green, Blue, White	1000LMF 1,000 Lumens per foot	<blank> Lambertian DAS Direct asymmetric distribution WG Wall Graze Distribution 1. Direct Distribution options are only available with FLL Direct Shielding and OD Lens Regress Depth option.	SCT Single Circuit	DARK Constant Current, Dimming to 0.1%

--	--	--	--	--	--

Optional Shielding	Voltage	Finish	Control Input	END Option	Options
CLL ^{3,5} Continuous Flush Lens FLL ⁴ Flush Lens LVRR ^{1,2} Louver (painted same finish color as housing) LVRRRA ^{1,2} Natural Aluminum Louver 1. Not available with TG trim. 2. Only available in whole foot increments. 3. CLL is not available with DAS or WG distributions. 4. When using distribution options, FLL will change to FLLC to designate a co-extruded lens with white and clear material. 5. 40-foot maximum uninterrupted length.	MVOLT 120-277V	WHTT White (Satin) AMF Antimicrobial White BLKT Black (Satin) SLVT Silver (Satin) RALTB ¹ RAL Paint Finish 1. RALTB is for pricing only. Replace with applicable RAL number & sheen when placing order	DMX DMX	W2W Wall to Wall (Both Ends Terminate at Wall) P2P Pocket to Pocket (Both Ends Terminate at Ceiling) N2N No Show Wall to No Show Wall (Both Ends Terminate at Wall) W2P Wall to Pocket (Start Terminates at Wall & End Terminates at Ceiling) P2W Pocket to Wall (Start Terminates at Ceiling & End Terminates at Wall) N2P No Show Wall to Pocket (Start Terminates at Wall & End Terminates at Ceiling) P2N Pocket to No Show Wall (Start Terminates at Ceiling & End Terminates at Wall) N2W No Show Wall to Wall (Both Ends Terminate at Wall) W2N Wall to No Show Wall (Both Ends Terminate at Wall)	<blank> No Options CP Chicago Plenum BAA Buy America(n) Act and/or Build America Buy America Qualified

PHOTOMETRICS

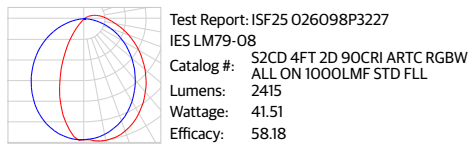
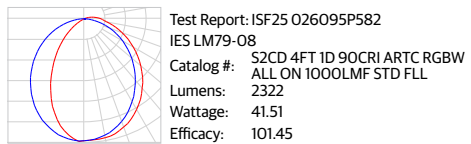
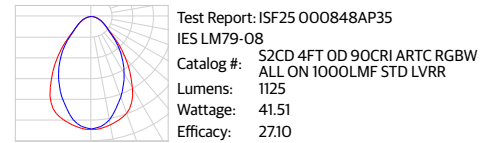
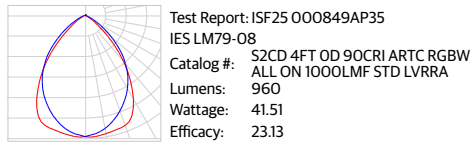
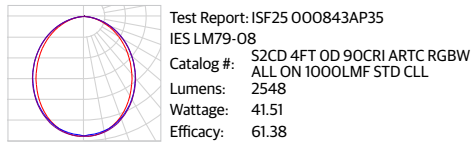
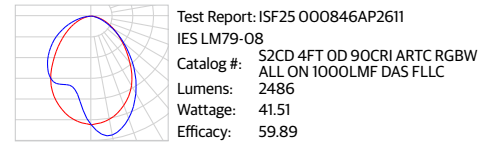
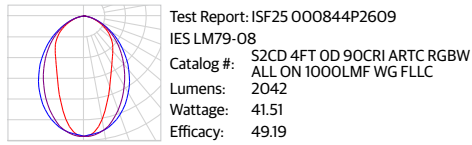
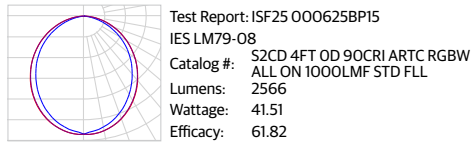

PROJECT LED LUMEN MAINTENANCE

Data references the extrapolated performance projections for the platforms noted in a 25°C ambient, based on 10,000 hours of LED testing (tested per IESNA LM-80-08 and projected per IESNA TM-21-11).
To calculate LLF, use the lumen maintenance factor that corresponds to the desired number of operating hours below. For other lumen maintenance values, contact factory.

Operating Hours	0	10,000	60,000	100,000
Lumen Maintenance Factor	1	0.98	0.84	0.75

OPTICAL SCALING CHARTS

DISTRIBUTIONS	MULTIPLIER
LAMBERTIAN	1.00
DAS	0.97
WG	0.80
SHIELDING	MULTIPLIER
LVRR	0.44
LVRRRA	0.37
CLL	0.99
FLL	1.00

*Base fixture with Lambertian distribution and flush lens (FLL)

REGRESS DEPTH SCALING CHART

LENS REGRESS DEPTH	MULTIPLIER
OD	1.00
1D	0.90
2D	0.94

*Base fixture with Lambertian distribution, 0" depth lens regress (OD), and flush lens (FLL)

RGBW GAMUT AND RANGE

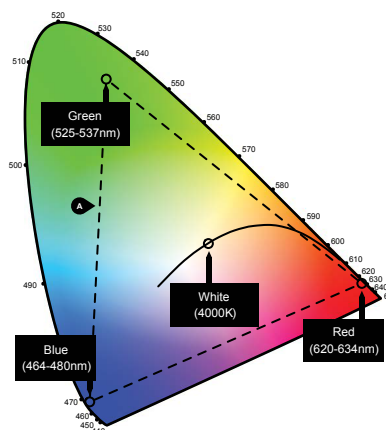

ARCHITAINMENT COLOR GPHD

- Gamut: Triangular
- Path: Full RGB gamut
- Handle: Four Handles: Red, Green, Blue, White
- Data: DMX512/RDM

Ⓐ RGBW Range within triangle formed by RGB

CEILING TRIMS

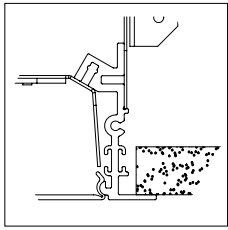

FL
5/8IN Flange (sheetrock)
Install Before Sheetrock

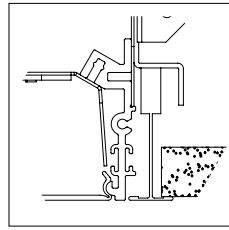

TG
9/16" Flat Tee w/ Lay-in Tile

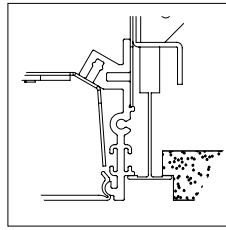

TG
9/16" Flat Tee w/ Tegular Tile

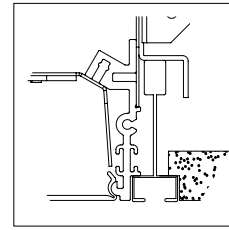

TG
9/16" Slot Tee w/ Tegular Tile

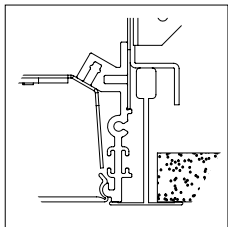

TG
15/16" Flat Tee w/ Lay-in Tile

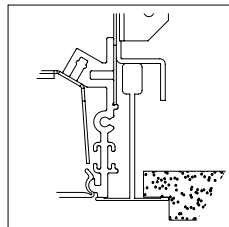

TG
15/16" Flat Tee w/ Tegular Tile

LINEAR PLAN

Mark Lighting calculates a continuous run based on optimizing fixture section length and options selected.

LOP- Linear Optimized Length

This linear plan supplies the run length based on defined length combinations, resulting in an optimized solution with the fewest segments. LOP

8FT	4FT	3FT
-----	-----	-----

Total Run Length

This system is not modular. Runs longer than 8FT will be automatically configured with left, intermediate, and right sections based on nomenclature ordered. Always order the total run length required and not individual sections.

Example: This run to be ordered as one 32FT run.

8FT	8FT	8FT	8FT
-----	-----	-----	-----

Example: This run to be ordered as four 8FT runs. Note: Individual fixtures sections cannot be joined together in the field.

8FT	8FT	8FT	8FT
-----	-----	-----	-----

MOUNTING

FL Trim Run

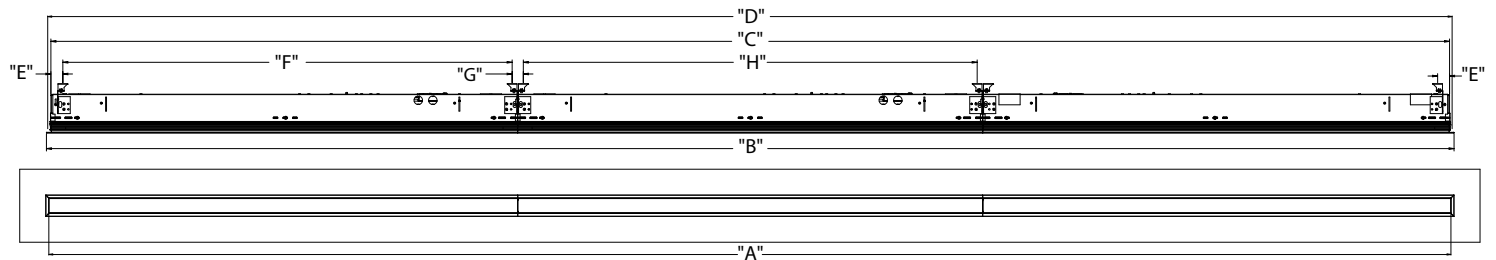

FL Run Configurations							
"A" (Illuminated Lenth)	"B" (Trim Length)	"C" (Housing Lenth)	"D" (Cut Opening Lenth)	"E" (End Mounting Location)	"F" (End Fixture Middle Mounting Point)	"G" (Mounting Point to Mounting Point)	"H" (Mounting Point to Mounting Point Intermediate Fixtures)
Order Length	Order length + 3/16" (W2W, W2N, N2W, N2N) Order length + 1 1/8" (P2P) Order length + 5/8" (W2P, P2W, N2P, P2N)	Order Length + 3/8"	Order length + 13/16"	13/16"	Fixture length - 1 1/2"	1 1/16"	Fixture length - 1 1/16"

TG Trim Run

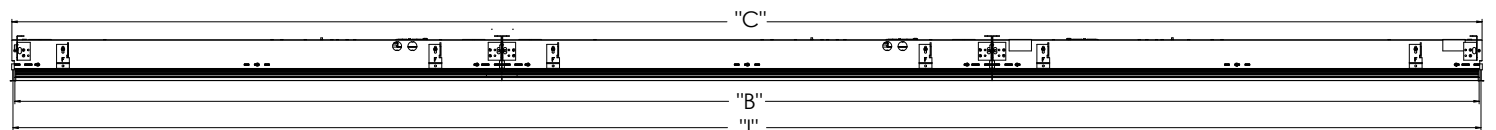

Grid Run Configurations			
"A" (Illuminated Lenth)	"B" (Trim Length)	"C" (Housing Lenth)	"I" (Grid Center to Center)
Order Length - 13/16"	Ordered Length - 5/8"	Order length - 1/32"	Order length + 13/16"

MOUNTING (continued)

Ceiling Cut Out Dimensions

		2-Foot	3-Foot	4-Foot	5-Foot	6-Foot	7-Foot	8-Foot
TG (BASED ON GRID CENTERLINE TO WALL SPACING)	GRID CL LENGTH(IN)	24	36	48	60	72	84	96
	GRID CL WIDTH(IN)	3.75 - 4.2	3.75 - 4.2	3.75 - 4.2	3.75 - 4.2	3.75 - 4.2	3.75 - 4.2	3.75 - 4.2
FL	LENGTH(IN) - W2W, W2N, N2W, N2N	24.18	36.18	48.18	60.18	72.18	84.18	96.18
	LENGTH(IN) - P2P	24.375	36.375	48.375	60.375	72.375	84.375	96.375
	LENGTH(IN) - W2P, P2W, N2P, P2N	24.25	36.25	48.25	60.25	72.25	84.25	96.25
	WIDTH(IN)	3.93-4.38	3.93-4.38	3.93-4.38	3.93-4.38	3.93-4.38	3.93-4.38	3.93-4.38

CEILING OPENING DIMENSIONS FOR INSTALLATION, +0.13"/-0.00"

FIXTURE DIMENSIONS AND WEIGHTS

		2-Foot	3-Foot	4-Foot	5-Foot	6-Foot	7-Foot	8-Foot
Individual	GRID CL (IN)	24	36	48	60	72	84	96
	OVERALL LENGTH (IN)	23.375	35.375	47.375	59.375	71.375	83.375	95.375
	HOUSING LENGTH (IN)	23.969	35.969	47.969	59.969	71.969	83.969	95.969
	APERTURE (IN)	23.165	35.165	47.165	59.165	71.165	83.165	95.165
TG Left or Right	GRID CL(IN)	24	36	48	60	72	84	96
	PRODUCT LENGTH(IN)	23.688	35.688	47.688	59.688	71.688	83.688	95.688
	HOUSING LENGTH(IN)	23.969	35.969	47.969	59.969	71.969	83.969	95.969
	APERTURE(IN)	23.567	35.567	47.567	59.567	71.567	83.567	95.567
Intermediate	GRID CL(IN)	24	36	48	60	72	84	96
	PRODUCT LENGTH(IN)	24	36	48	60	72	84	96
	HOUSING LENGTH(IN)	23.969	35.969	47.969	59.969	71.969	83.969	95.969
	APERTURE(IN)	24	36	48	60	72	84	96

		2-Foot	3-Foot	4-Foot	5-Foot	6-Foot	7-Foot	8-Foot
Individual	APERTURE(IN)	24	36	48	60	72	84	96
	PRODUCT LENGTH(IN) - W2W, W2N, N2W, N2N	24.180	36.180	48.180	60.180	72.180	84.180	96.180
	PRODUCT LENGTH(IN) - P2P	25.125	37.125	49.125	61.125	73.125	85.125	97.125
	PRODUCT LENGTH(IN) - W2P, P2W, N2P, P2N	24.652	36.652	48.652	60.652	72.652	84.652	96.652
	HOUSING LENGTH(IN)	24.375	36.375	48.375	60.375	72.375	84.375	96.375
FL Left	APERTURE(IN)	24	36	48	60	72	84	96
	PRODUCT LENGTH(IN) - W2x, N2x	24.090	36.090	48.090	60.090	72.090	84.090	96.090
	PRODUCT LENGTH(IN) - P2x	24.562	36.562	48.562	60.562	72.562	84.562	96.562
	HOUSING LENGTH(IN)	24.188	36.188	48.188	60.188	72.188	84.188	96.188
Right	APERTURE(IN)	24	36	48	60	72	84	96
	PRODUCT LENGTH(IN) - x2W, x2N	24.090	36.090	48.090	60.090	72.090	84.090	96.090
	PRODUCT LENGTH(IN) - x2P	24.562	36.562	48.562	60.562	72.562	84.562	96.562
	HOUSING LENGTH(IN)	24.188	36.188	48.188	60.188	72.188	84.188	96.188
Intermediate	APERTURE(IN)	24	36	48	60	72	84	96
	PRODUCT LENGTH(IN)	24	36	48	60	72	84	96
	HOUSING LENGTH(IN)	23.969	35.969	47.969	59.969	71.969	83.969	95.969

*All values rounded to +/- 1/16"

Approximate Fixture Section Weights	2-Foot	3-Foot	4-Foot	5-Foot	6-Foot	7-Foot	8-Foot
WEIGHT(LBS)	10	13	16	23	25	28	31

DIRECT SHIELDING & OPTIONS

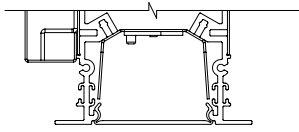

Flush Lens (FLL)
Continuous Lens (CLL)

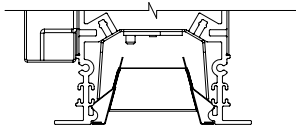

Louver (LVRR)
Aluminum Louver
(LVRR) Painted

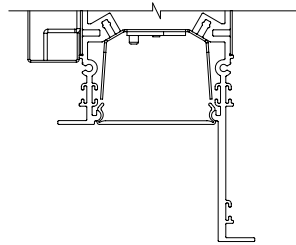

2" Regress with
FLL or CLL

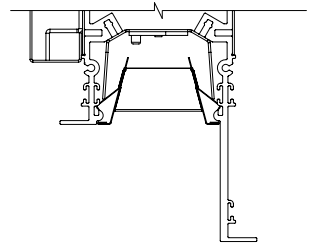

2" Regress with
LVRR or LVRR

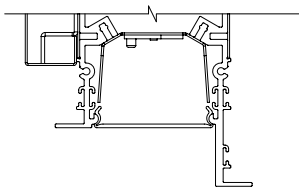

1" Regress with
FLL or CLL

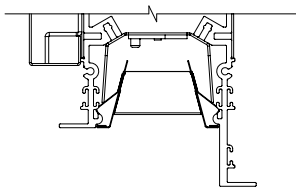

1" Regress with
LVRR or LVRR

DIRECT DISTRIBUTION

Optical Film for DAS and WG distributions with co-extruded lens standard.
Direction of light for DAS or WG distribution will be in the direction of the notches on the film.

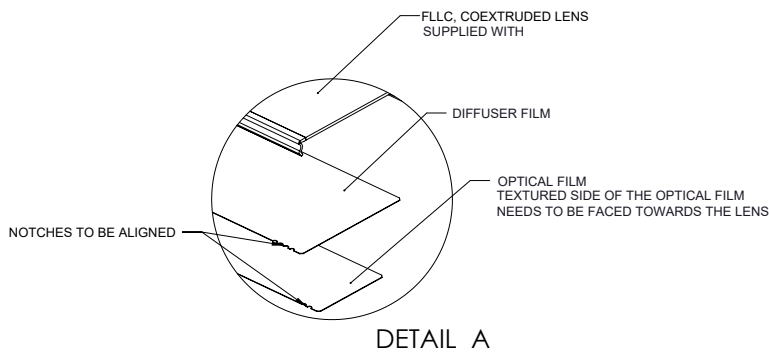

Optical Film	Number of Notches
Diffuser	4
Direct Asymmetric (DAS)	1
Wall Graze (WG)	3

CONTINUOUS LENS

40-foot maximum uninterrupted length. From 40-foot 1/8-inch to 106-foot, visible joiner required and supplied with lens rolls. Joiner will match color of trim. Continuous lens and joiners, if required, ship separate from the fixture. Reference installation instructions for further details and steps.

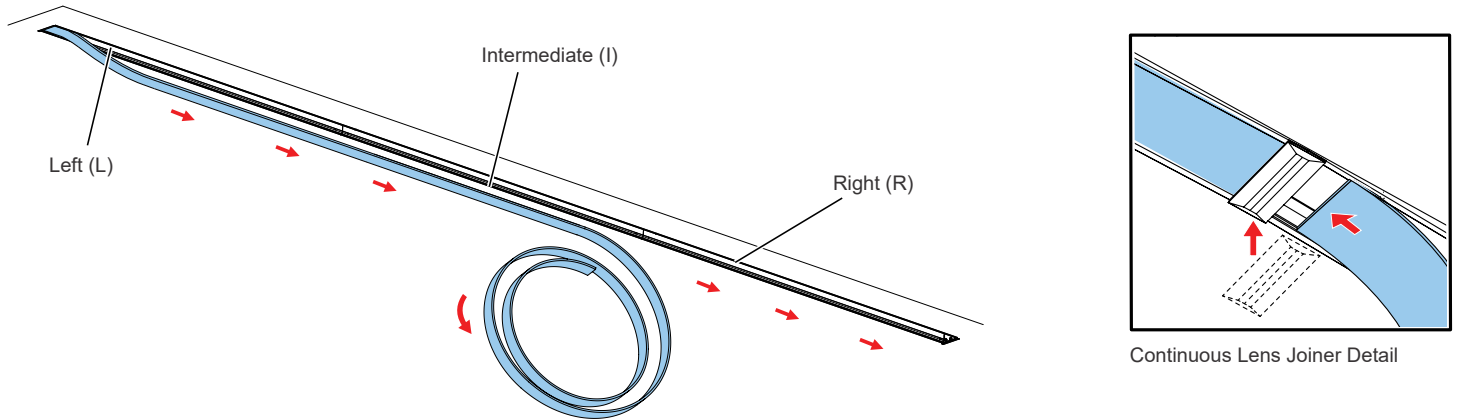

RUN PATTERNS, CORNERS, & JUNCTIONS

Patterns can be configured in 1' increments with illuminated L (corner), X, Y, & T connectors. Standard corner has 2' leg segments. Standard L (corner) connector angles are available in 40-179 degrees in 1 degree increments. Standard T & Y connector angles are available in 40-179 degrees in 1 degree increments. Standard X connector angle available in 40-90 degrees in 1 degree increments.

See separate pattern spec sheet for more details.

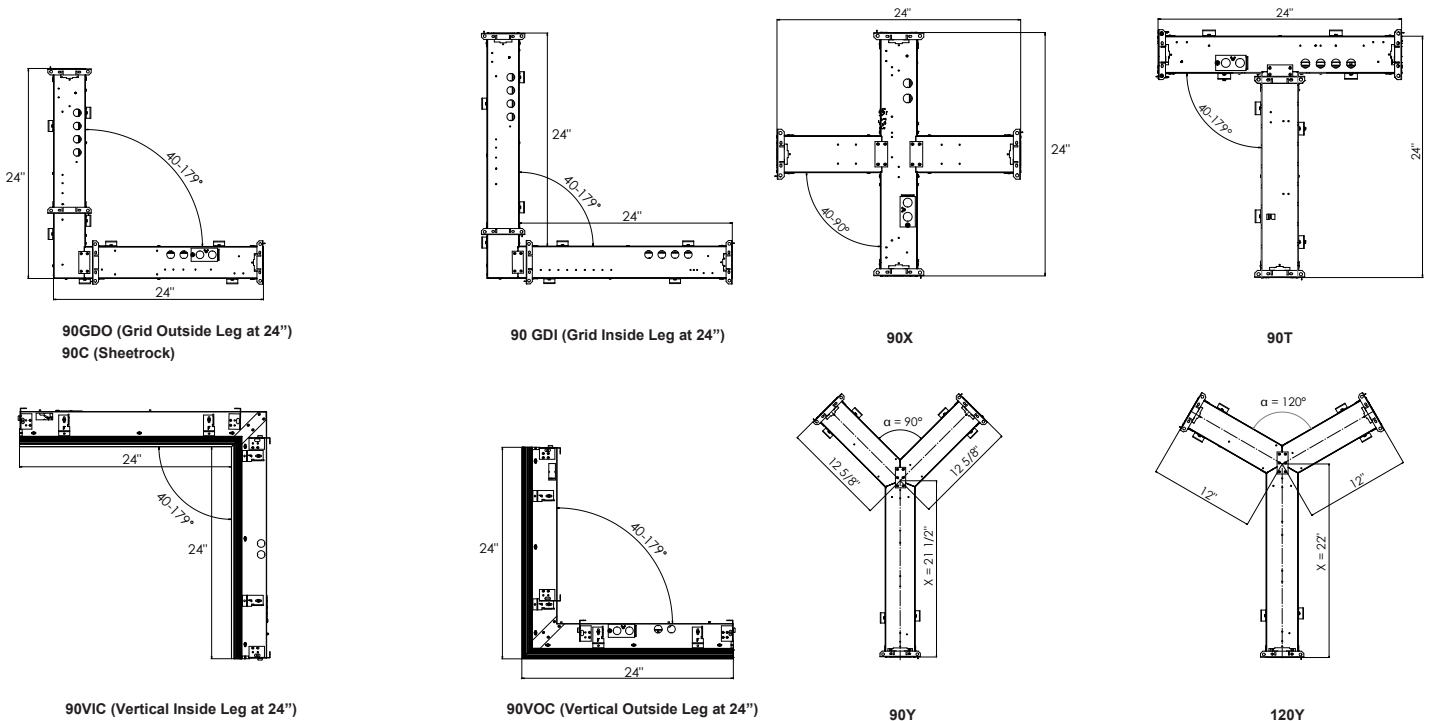

NOTE: For Y intersections, dimension X varies depending on the angle α .
Angle α can be in a range of 40-179°.

ENDPLATE DETAIL

FL Trim Run

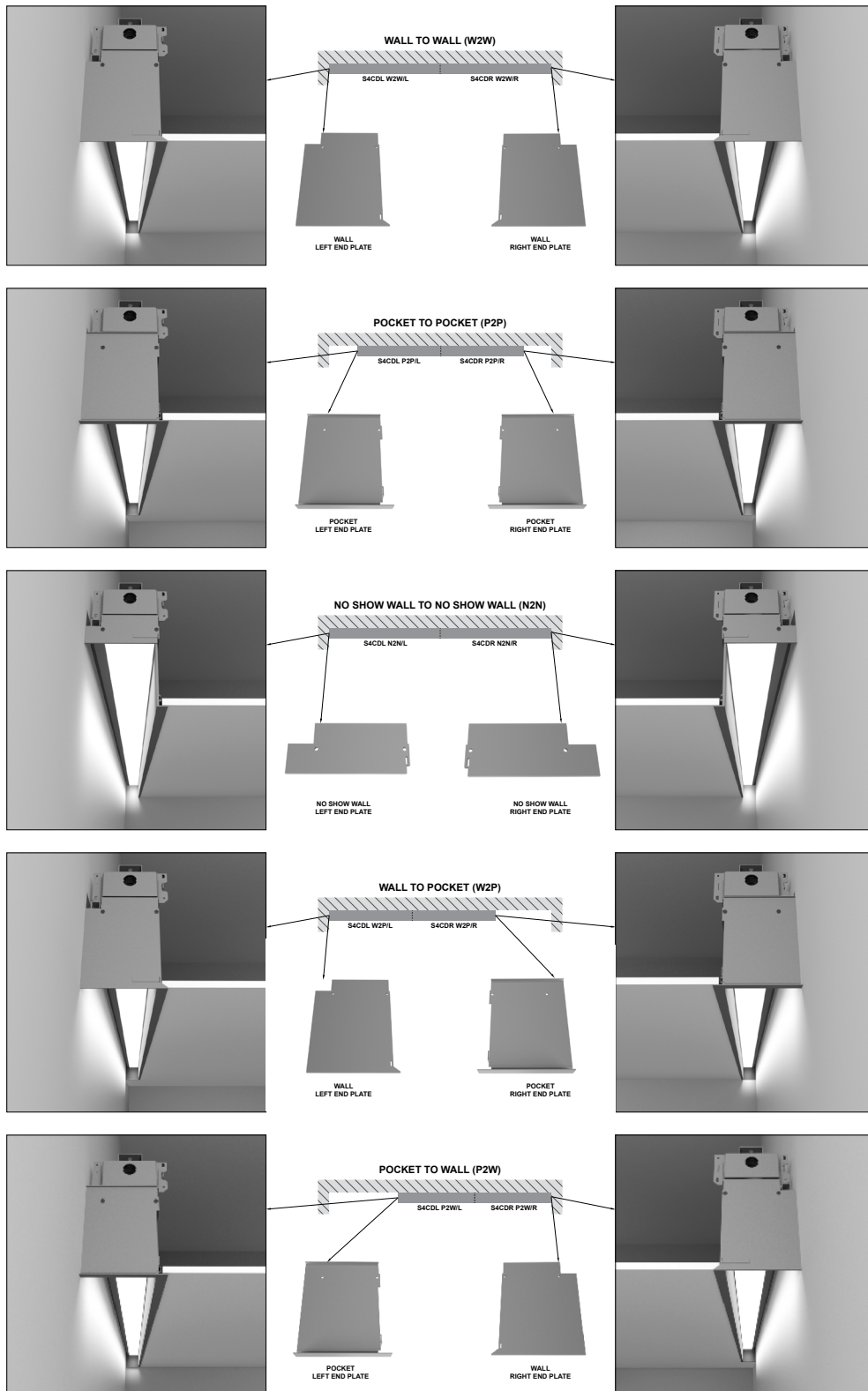

ENDPLATE DETAIL (continued)

FL Trim Run

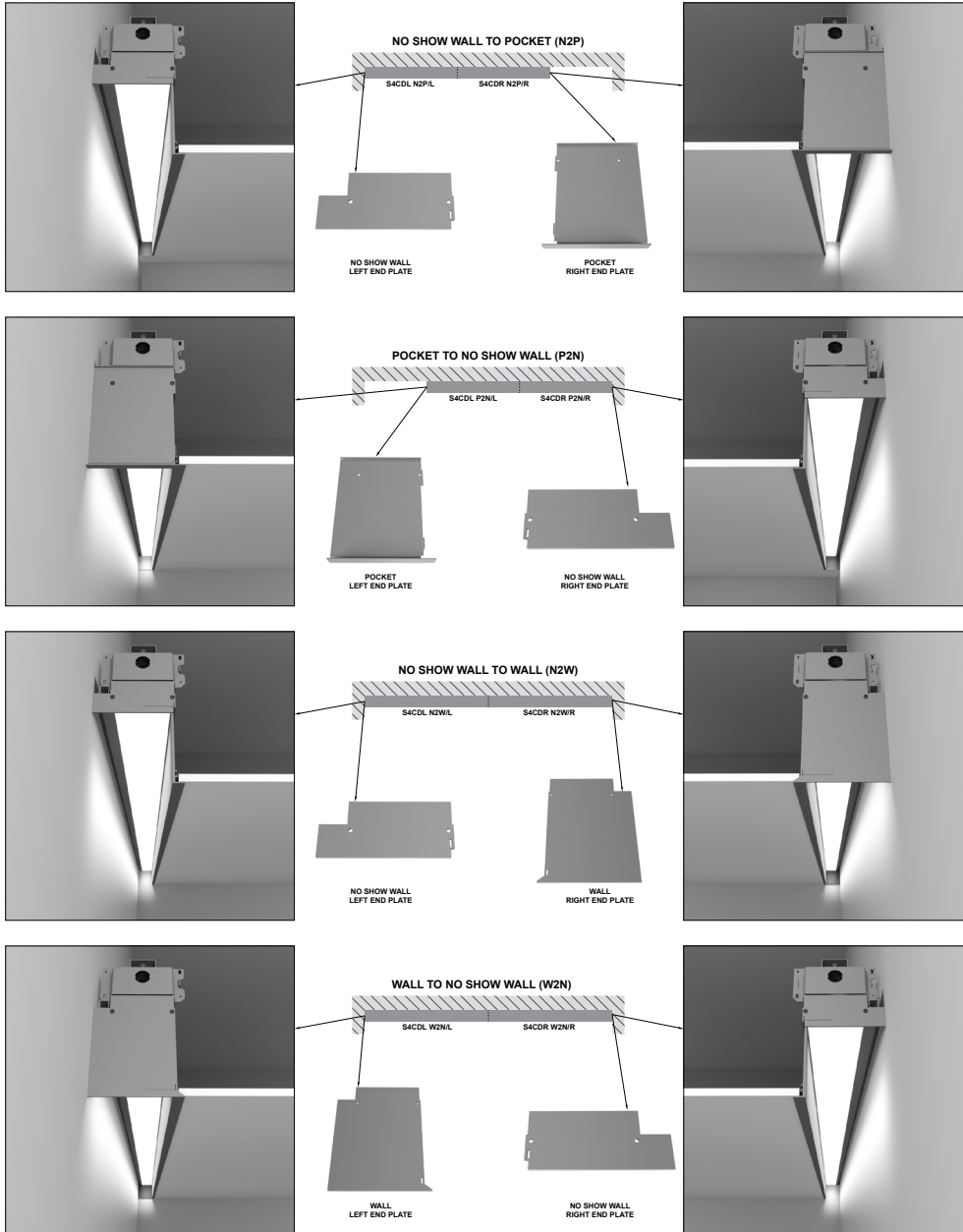

ENDPLATE DETAIL (continued)

TG Trim Run

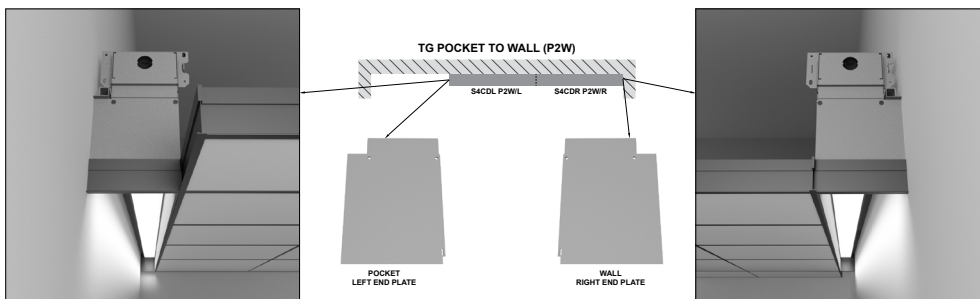
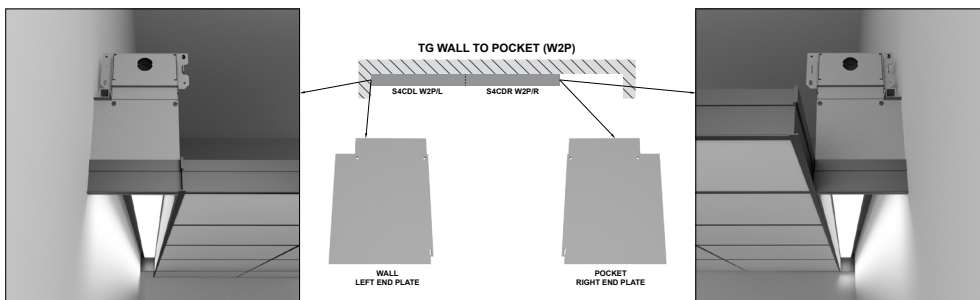
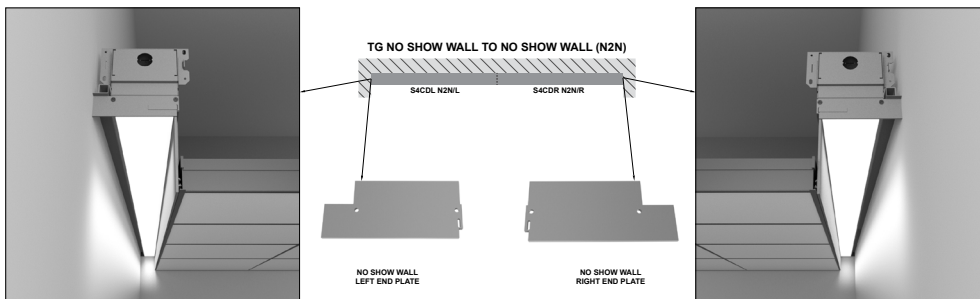
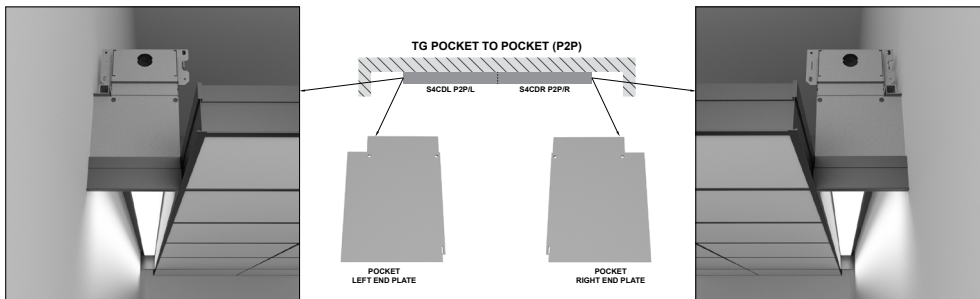
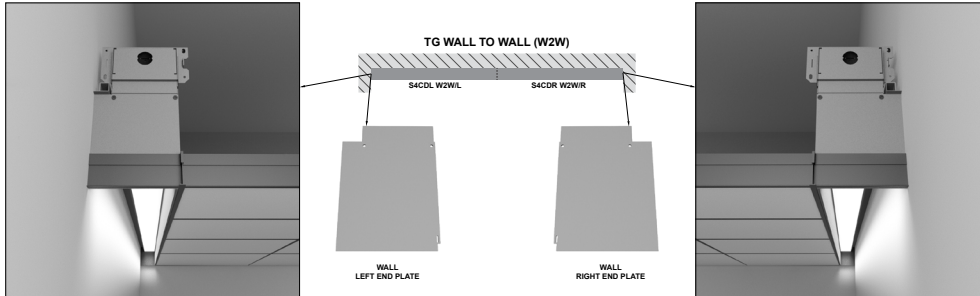

ENDPLATE DETAIL (continued)

TG Trim Run

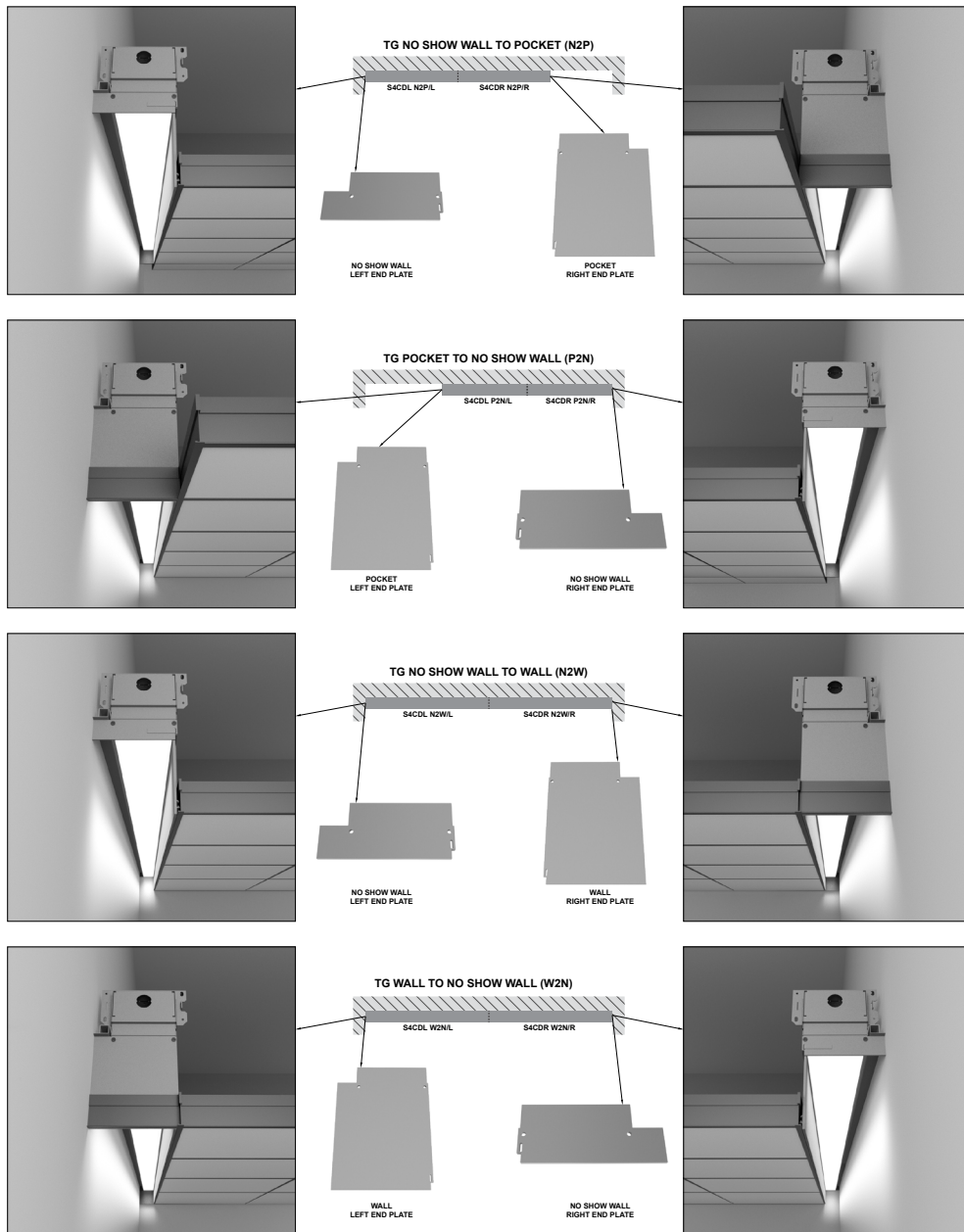

INTELLIGENT LUMINAIRE GUIDE

Choose nomenclature from these columns

Driver Configuration (MVOLT)	Minimum Dimming Level	+	Control Input	=	Driver	Dimming Range	Notes
	DARK		DMX		eldoLED Powerdrive DMX/RDM Compatible		

BASIC SYSTEM WIRING INFORMATION WITH DMX

This very basic system wiring diagram provides an overview of components and materials required for a simple installation of Slot Recessed luminaires controlled by a DMX controller. These diagrams should not be used in place of actual installation instructions or submittal drawings prepared for a specific project.

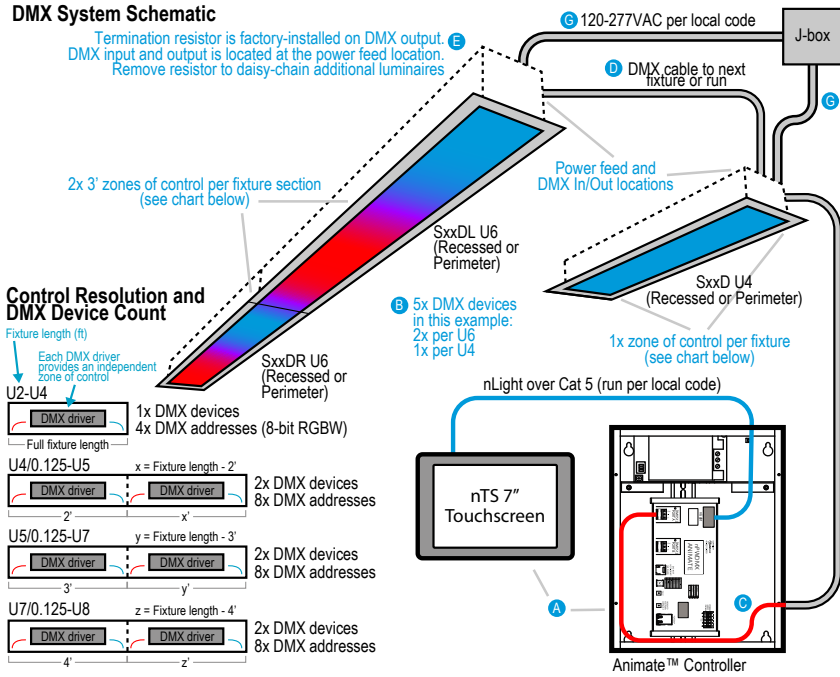

- A** DMX controller providing DMX-512 control. To supply a complete system DMX/RDM set-up and playback control solution, use one of the following options:
 - Animate™ Controller by nLight® with nTS Touchscreen by nLight®
 - DMX control on the nLight network for smooth fades and stunning dynamics
 - Control up to 500 RGBx zones with maximum "pixel" resolution with U4 option
 - Built-in logic engine to automate lighting rhythms, holiday Looks and scheduling
 - Program with Pathscope software from Pathway Connectivity Solutions®, loaded with built in effects allowing unlimited control of color, speed and transitions
 - Not compatible with Fresco
 - nPWDMX ANIMATE U1 controls up to 128 RGBx zones and provides two DMX runs (each run supports 32 DMX devices and 1000ft of total cable length) Add one or more PWREP splitters for systems with more than 64 DMX devices.
 - Fresco
 - Manage multiple light sources in multiple lighting zones, all from one controller
 - On screen lighting design and set-up, no computer required or Ethernet connection for remote configuration and advanced control
 - All device settings are stored on-board in non-volatile memory
 - Not compatible with Animate™ Controller
 - Fresco provides one DMX run. Add one or more PWREP splitters for systems with more than 32 DMX devices
- B** A maximum of 32 DMX Devices can be connected to a single DMX run from any DMX controller. The maximum length of cord and luminaire run combined is 1000 feet per DMX/RDM specification.
- C** DMX run to luminaires. Belden 9829 cable is the preferred communication/data cable used to carry the DMX signal to and from the controllers and luminaires. The total length of this cable must not exceed 1000 feet from the DMX controller to the last DMX device. No luminaires should be installed between DMX Controller and any PWREP. Belden 9829 cable is not plenum rated, so run in conduit per local code in plenum spaces.
- D** Data can be daisy-chained from fixture to fixture in conduits. Use Belden 9829 for data and do not exceed the maximum DMX device count or cable run length per DMX run. Consult fixture installation instructions for fixture connection and termination recommendations.
- E** To ensure data integrity, a termination with 120 Ohm resistor is required on the DMX output of the last luminaire in each run. Mark Slot fixtures have DMX input and output at the feed location of all feed fixtures (PWRF in fixture nomenclature) with a 120 Ohm resistor factory-installed on the output. Remove for daisy-chaining to additional fixtures or runs. See installation instructions for detail.
- G** Power should be run to luminaire junction box locations in conduits per local code.

PATHWAY CONNECTIVITY SOLUTIONS - DMX NETWORKING AND ADVANCED CONTROL

DMX512 networks create dynamic lighting. Dynamic lighting often brings a lot of color and movement to spaces. The DMX512 lighting protocol was created to serve the needs of performance lighting, such as in theaters or music venues. A DMX network is designed to support large amounts of data continually moving between controllers and luminaires, and at very high speeds. Many non-performance lighting applications also rely on DMX networks, to support RGB LED luminaires featured in applications such as building façades, hotel lobbies and corporate reception areas.

A DMX network always includes a controller and luminaires that are compatible with the DMX protocol. Also, DMX lighting systems must include network devices that route the DMX data to different locations between the controllers and luminaires.

Pathway Connectivity provides these network devices, creating robust and secure network backbones. Pathway devices create bridges between Ethernet and DMX, and DMX and other kinds of lighting control protocols, such as RDM, nLight® or 0-10v.

DMX Splitter

Model
PWREP WM REPEATER DMX/RDM OPTO-SPLITTER (Must be purchased separately)

The PWREP serves as a 4-run splitter enabling up to 128 DMX devices to be controlled from a single device. Use for installations containing more DMX devices than can be supported by your controller's outputs. Refer to the PWREP spec sheet for dimensions and mounting details.



PWREP DMX/RDM Opto-Splitter [PWREP WM P4 TERM RDM]

nTS Touchscreen by nLight® [nTS 7IN]



Animate™ Controller by nLight® [nPWDMX ANIMATE...U1]



Fresco Control System [FCS 7TSN X]



SPECIFICATIONS

Housing

Nominal 2" x 2', 3', 4', 5', 6', 7', 8' and continuous rows in 1/8" increments starting at 2', as standard. Upper housing fabricated from cold-rolled steel with extruded aluminum ceiling trim.

Finish

Standard colors for fixture trims are polyester powder coated white, anti-microbial white, black, or silver with satin sheen. Consult factory for custom colors or specify RAL colors from Architectural brochure.

Reflector

Precision-formed steel; high reflectance matte white powder coat; 93% reflectivity.

Optics (Distribution)

Wall Graze (WG) and Direct Asymmetric (DAS) incorporate co-extruded lenses and films.

Lenses/Shielding

Extruded acrylic lens, (CLL, FLL). Aluminum louver with either a powder coat finish to match housing color (LVRR) or aluminum finish (LVRRRA).

Mounting

Sheetrock: Recessed ceiling only to accommodate sheetrock, 1/2" minimum to 1-1/2" maximum depth for FL trim option.

Grid: To accommodate 9/16" Flat Tee with Lay-In Tile, 9/16" Flat Tee with Tegular Tile, 9/16" Slot Tee with Tegular Tile, 15/16" Flat Tee with Lay-In Tile, & 15/16" Flat Tee with Tegular Tile for TG trim option.

LED Source

LED's in a single row at 1:1 ratio (1xRed, 1xGreen, 1xBlue, 1xWhite) Red (623 nm), Green (528nm), Blue (470nm) and White 4000K 90CRI diodes provide a full range of color. The Acuity Brands circuit boards for the linear LED components use a precise binning algorithm which creates a consistent color temperature from board to board. Color variation of no greater than a 2.5 Step MacAdam (2.55DECM) along the black body locus from board to board.

Electrical

Long-life LEDs, coupled with high-efficiency drivers, provide superior quantity and quality of illumination for extended service life. 90% LED lumen maintenance at 60,000 hours (L90/60,000).

Circuits

Single switching option only.

Dimming Driver

Factory tuned constant current electronic dimming driver is standard. Flicker free dimming available down to <1%. LED drivers perform within the recommended operating areas for flicker as a function of frequency and modulation (%) IEEE Standard 1789-2015 (IEEE Recommended Practices for Modulating Current in High-Brightness LEDs for Mitigating Health Risks to Viewers), in typical operating conditions at representative dimming levels. Electrical specifications at maximum driver load: PF > 0.9 and THD <20%. Meets FCC Title 47 Class A or Class B. All drivers are RoHS compliant.

Controls System Networking Options

DMX512/remote device management protocol, may be controlled with EasyL, Fresco, or any DMX512 interface system.

Resolution(DMX/RDM)

Resolution varies depending upon length of fixture.

U2 - U4 = 1 DMX Device (complete fixture length)

U4/0.125 - U5 = 2 DMX devices (2-foot length & remaining length)

U5/0.125 - U7 = 2 DMX devices (3-foot length & remaining length)

U7/0.125 - U8 = 2 DMX devices (4-foot length & remaining length)

Ambient Operating Temperature Range

-20°C (-4° F) to +25°C (+77°F)

Environment

Suitable for damp location. Indoor use only.

Certification

CSA certified to meet U.S. and Canadian standards (UL1598 and UL8750). This product is IC rated.

Fixture Weight

Approximately 4.0 lbs per foot, less packaging.

Government Procurement

BAA - Buy America(n) Act: Product qualifies as a domestic end product under the Buy American Act as implemented in the FAR and DFARS. Product also qualifies as manufactured in the United States under DOT Buy America regulations.

BABA - Build America Buy America: Product qualifies as produced in the United States under the definitions of the Build America, Buy America Act.

Please refer to www.acuitybrands.com/buy-american for additional information.

Warranty

5-year limited warranty. This is the only warranty provided and no other statements in this specification sheet create any warranty of any kind. All other express and implied warranties are disclaimed. Complete warranty terms located at: www.acuitybrands.com/support/warranty/terms-and-conditions

Notes: Actual performance may differ as a result of end-user environment and application.

All values are design or typical values, measured under laboratory conditions at 25°C.

Specifications subject to change without notice